

NACA

RESEARCH MEMORANDUM

for the

U. S. Air Force

HOVERING AND TRANSITION FLIGHT TESTS OF A 1/5-SCALE
MODEL OF THE RYAN X-13 VTOL AIRPLANE

COORD. NO. AF-199

By Charles C. Smith, Jr.

Langley Aeronautical Laboratory
Langley Field, Va.

Declassified by authority of NASA
Classification Change Notices No. 215

** 12/31/71

FF No. 602(A)	X71-81426	(ACCESSION NUMBER)	(THRU)
	<u>34</u>	(PAGES)	<u>None</u>
		(NASA CR OR TMX OR AD NUMBER)	(CATEGORY)
	Restriction/Classification Cancelled ONLY		

NATIONAL ADVISORY COMMITTEE
FOR AERONAUTICS
WASHINGTON

SEP 8 1951

NATIONAL ADVISORY COMMITTEE FOR AERONAUTICS

RESEARCH MEMORANDUM

for the

U. S. Air Force

HOVERING AND TRANSITION FLIGHT TESTS OF A 1/5-SCALE
MODEL OF THE RYAN X-13 VTOL AIRPLANE*

COORD. NO. AF-199

By Charles C. Smith, Jr.

SUMMARY

An experimental investigation has been made to determine the dynamic stability and control characteristics of a 1/5-scale flying model of the Ryan X-13 jet VTOL airplane in hovering and transition flight. The model was powered with either a hydrogen peroxide rocket motor or a compressed-air jet exhausting through an ejector tube to simulate the turbojet engine of the airplane. The gyroscopic effects of the engine were simulated by a flywheel driven by compressed-air jets. In hovering flight the model was controlled by jet-reaction controls which consisted of a swiveling nozzle on the main jet and a movable nozzle on each wing tip; and in forward flight the model was controlled by elevons and a rudder.

If the gyroscopic effects of the jet engine were not represented, the model could be flown satisfactorily in hovering flight without any automatic stabilization devices. When the gyroscopic effects of the jet engine were represented, however, the model could not be controlled without the aid of artificial stabilizing devices because of the gyroscopic coupling of the yawing and pitching motions. The use of pitch and yaw dampers made these motions completely stable and the model could then be controlled very easily. In the transition flight tests, which were performed only with the automatic pitch and yaw dampers operating, it was found that the transition was very easy to perform either with or without the engine gyroscopic effects simulated, although the model had a tendency to fly in a rolled and sideslipped attitude at angles of attack between approximately 25° and 45° because of static directional instability in this range.



INTRODUCTION

At the request of the U. S. Air Force, an investigation has been made to determine the dynamic stability and control characteristics of a 1/5-scale flying model of the Ryan X-13 turbojet VTOL airplane in hovering and transition flight. The airplane has a modified triangular wing and a modified triangular vertical tail mounted on top of the wing and has no horizontal tail. Take-offs and landings with the airplane in a vertical attitude are made from a horizontal wire with a special hook-on attachment on the nose of the airplane. For convenience, however, the airplane also had a tricycle landing gear to permit conventional take-offs from and landings on the ground so that the initial transitions could be performed at a safe altitude. Control for hovering flight is provided by jet-reaction controls which consist of a swiveling nozzle on the main jet for pitch and yaw control and of small nozzles utilizing engine-bleed air on the wing tip for roll control. Aerodynamic controls consisting of elevons and rudder are provided for control in normal forward flight.

The present investigation consisted mainly of flight tests of the model in take-offs and landings, hovering flight, and transition between hovering and unstalled forward flight. A few force tests were also made in the transition condition in order that the flight-test results might be better understood. The hovering flight tests consisted of unrestrained hovering flights with and without artificial stabilization in pitch and yaw and with and without the gyroscopic forces of the jet engine represented. Take-offs and landings from a horizontal wire were also made. The effects of rotating the swiveling nozzle to obtain a cross coupling of the pitch and yaw controls in an attempt to counteract the effect of the gyroscopic forces of the jet engine were also determined. The transition flights were constant-altitude transitions and covered an angle-of-attack range from about 20° to 90° and a speed range of 0 to 110 knots (full scale). Both rapid and very slow transition flights were made. The slow transitions were made in completely free flight in the Langley full-scale tunnel, and the rapid transitions were made on the Langley control-line facility which uses the control-line technique in which the model is restrained in the lateral degrees of freedom but has longitudinal freedom.

Almost all of the tests were conducted with hydrogen-peroxide-decomposition rockets used for power because that was the most practical source of jet power for the model available at the time the investigation was started. Because of the danger to the facilities of fire from spilled hydrogen peroxide, it was decided to conduct the initial tests outdoors until sufficient safety and equipment reliability were proven to justify using the hydrogen peroxide for wind-tunnel or other

indoor tests. During the time that these initial flight tests were being conducted and the hydrogen peroxide equipment was being developed, a supply of compressed air became available for use in the full-scale tunnel and the building containing the hovering test area which permitted the model to be powered with compressed-air jets instead of hydrogen peroxide. The transition tests in the full-scale tunnel and the few remaining hovering tests were therefore conducted with the model powered with compressed air.

The results of the flight investigation were obtained mainly from the observations made by the pilots of the stability, controllability, and general flight behavior of the model. These results were supplemented by motion-picture records of the flights.

NOMENCLATURE AND SYMBOLS

In order to avoid confusion in terminology which might arise because of the large range of operating attitudes of the model, it should be noted that the controls and motions of the model are referred to in conventional terms relative to the body system of axes; that is, the rudder on the vertical tail and the deflection of the jet to the left or right by the swiveling nozzle produced yaw about the normal body axis, differential deflection of the elevons and the wing-tip nozzles produced roll about the fuselage axis, and simultaneous up or down deflections of the elevons and deflection of the jet up or down by use of the swiveling nozzle produced pitch about the spanwise axis.

The symbols used are as follows:

\bar{c}	mean aerodynamic chord
ϕ	angle of bank about fuselage axis, deg
β	angle of sideslip, deg
α	angle of attack of fuselage, deg
i_f	fuselage incidence angle (angle between longitudinal fuselage axis and relative wind), deg
V	velocity, ft/sec
S	wing area, sq ft
b	wing span, ft

q	dynamic pressure $\frac{\rho V^2}{2}$, lb/sq ft
ρ	mass density
δ_e	simultaneous deflection of elevons, deg
δ_a	differential deflection of elevons, deg
C_n	yawing-moment coefficient referred to body axis, $\frac{\text{Yawing moment}}{qSb}$
C_l	rolling-moment coefficient referred to body axes, $\frac{\text{Rolling moment}}{qSb}$
C_y	side-force coefficient referred to body axis, $\frac{\text{Side force}}{qS}$
I_ω	inertia of gyroscope about its spin axis multiplied by angular velocity about its spin axis, lb-in. ² /sec
I_x	moment of inertia about X-axis, slug-ft ²
I_y	moment of inertia about Y-axis, slug-ft ²
I_z	moment of inertia about Z-axis, slug-ft ²

APPARATUS AND TESTS

Model

Figures 1 and 2 are photographs of the model. In figure 2 the jet-reaction controls can be seen. A sketch showing some of the more important dimensions is shown in figure 3. The geometric characteristics of the model are presented in table I, and the mass characteristics are presented in table II.

The model was powered by either a 60-pound-thrust hydrogen-peroxide-decomposition rocket motor or compressed-air jets exhausting into an ejector tube. Photographs of the power plant are presented in figures 4 and 5, and a sketch illustrating the installation of the power plant in the model is presented in figure 6. The rocket motor or compressed-air jet when installed in this manner acted as a jet pump to produce a flow

of air through the model. It is desirable to represent the internal air flow since previous tests with models having large inlets ahead of the center of gravity have shown that the inlet air flow can have appreciable effects on stability in hovering flight and since the internal flow causes damping moments which might also have an important effect on stability in hovering flight. With the ejector system used in the model, it was possible to create an air flow of approximately twice the mass flow of the rocket and a thrust of 1.2 times that of the rocket. Under these conditions the inlet air flow was approximately 80 percent, and the exit air flow 120 percent, of the scaled-down mass flow of the full-scale airplane. The hydrogen peroxide was supplied to the rocket motor by a special pressurizing system that is described later. No measurements were made of the induced mass flow with the compressed-air jet used as the source of power. Analysis of the factors involved, however, indicate that the inlet air flow was approximately the same as that with the rocket used for power but that the exit mass flow was about 200 percent of the scaled-down-engine mass flow.

The model had a modified delta-wing and a vertical-tail surface with conventional flap-type elevon and rudder controls for use in forward flight. Pitch and yaw controls for hovering flight were provided by a swiveling nozzle at the end of the tail pipe which can be seen in figure 5. Roll control was provided by two small hydrogen peroxide rocket motors (or air jets), one on each wing tip, which were deflected differentially. The roll-control rockets are also evident in figure 5.

In most flights, the jet-reaction controls were operated by the flicker-type (full-on or off) pneumatic actuators generally used on models by the Langley free-flight tunnel section. These controls were equipped with an integrating-type trimmer which trimmed the control a small amount in the direction the control was moved each time a control deflection was applied. With actuators of this type, a model becomes accurately trimmed after flying a short time in a given flight condition. In some of the flights an electric trim motor was used to take care of large changes in trim.

Artificial stabilization in pitch and yaw was used in some of the flights. The sensing elements were rate gyroscopes which, in response to rate of pitch or yaw, provided signals to proportional control actuators which moved the main jet nozzle to oppose the pitching or yawing motion. A pilot-operated override was provided in the gyroscope-operated devices so that the pilot could have all the available control at his command. The operation of these devices was such that they provided damping in pitch or yaw regardless of the attitude of the model. The override cut out the damping action and applied all available control in the direction desired by the pilot.

The model was initially equipped with a conventional tricycle-type landing gear, but this landing gear was later removed in the flight tests in order to avoid the fouling of the flight cable. For the take-off and landing tests a special hook similar to that on the full-scale airplane was fastened to the nose.

The gyroscopic forces of the jet engine were simulated by a fly-wheel driven by air jets at speeds up to 43,000 rpm which gave a value of $I\omega$ of 39,300 lb-in.²/sec, approximately the correct scaled-down value for the airplane.

Test Equipment and Setup

Transition flight tests with complete freedom were conducted in the Langley full-scale tunnel. The take-off, landing, hovering, and rapid-transition flight tests were conducted on the Langley control-line facility. Additional hovering flight tests were conducted in a large building in connection with the preparation of the model for testing in the full-scale tunnel.

Figure 7 shows the test setup for the flight tests in the full-scale tunnel. The sketch shows the pitch pilot, the safety-cable operator, and the power operator on a balcony at the side of the test section. The roll pilot was located in an enclosure in the lower rear part of the test section, and the yaw pilot was at the top rear of the test section. The pitch, roll, and yaw pilots were located at the most advantageous points for observing and controlling the particular phase of the motion with which each was concerned. Motion-picture records were obtained with fixed cameras mounted near the pitch and yaw pilots.

The air for the main propulsion jets and for the jet controls was supplied through flexible plastic hoses, while the power for the electric trim motors and control solenoids was supplied through wires. These wires and tubes were suspended overhead and taped to a safety cable (1/16-inch braided aircraft cable) from a point approximately 15 feet above the model down to the model. The safety cable, which was attached to the top of the wing just ahead of the vertical tail of the model, was used to prevent crashes in the event of a power or control failure, or in the event that the pilots lost control of the model. During flight the cable was kept slack so that it would not appreciably influence the motions of the model. For the cases in which the model was powered with compressed air instead of hydrogen peroxide, the hose required to supply sufficient compressed air to the model was considerably larger than that required for supplying hydrogen peroxide, but its interference with the model motions was considered to be within tolerable limits.

The test technique is best explained by the description of a typical flight. The model hung from the safety cable, and the power was increased until the model was in steady hovering flight. At this point the tunnel drive motors were turned on and the airspeed began to increase. As the airspeed increased, the controls and power were operated so that the model tilted progressively into the wind in order to maintain its fore-and-aft position in the test section until a particular phase of the stability and control characteristics was to be studied. Then the pilots performed the maneuvers required for the particular tests and observed the stability and control characteristics. The flight was terminated by gradually taking up the slack in the safety cable while reducing the power to the model.

This same testing technique was used for the hovering flight tests except that the wind tunnel was not necessary. Some of these tests were conducted indoors in a large open building, with the model powered by compressed-air jets. Other hovering tests, with the model powered with the hydrogen-peroxide rockets were conducted at the Langley control-line facility with the crane boom serving as the overhead support for the flight cable.

The control-line facility is illustrated in figure 8 and described in detail in reference 1. Basically the control-line facility consists of a crane with a jib boom to provide an overhead support for the safety cable. The pilot and operators ride in the cab of the crane so that they will always face the model as it flies in a circle on the end of a restraining line. With this facility, rapid transition flights from hovering to normal forward flight can be made since the crane has a high rate of acceleration. The facility is mounted on a pedestal in the middle of a large concrete apron located in a wooded area which serves as a wind break.

The equipment for handling the hydrogen peroxide consisted mainly of two pieces: a system for pressurizing and controlling the flow of the hydrogen peroxide, and a trailer with a tank for transporting the hydrogen peroxide. This equipment is shown in figure 9. A simplified sketch of a hydrogen peroxide pressurizing system is presented in figure 10. The pressurizing system is enclosed in a cabinet and mounted on the crane so that the power operator can ride inside the cab and operate the necessary valves for operating the system and controlling the thrust of the rocket motor in the model. The 1/2-inch stainless steel tubing mounted on the boom of the crane carries the hydrogen peroxide from the pressurizing system to a remotely controlled safety cutoff valve on the end of the jib boom. A 1/4-inch flexible plastic hose covered with a Dacron braid carries the hydrogen peroxide from the end of the jib boom into the model.

Tests

The investigation consisted mostly of flight tests which were made in order to study the stability and control characteristics of the model. The stability and controllability were determined in various tests either qualitatively from the observations of the pilots or quantitatively from motion-picture records of the flights.

Transition flight tests.- Flight tests were made in the test section of the full-scale tunnel in order to determine the overall stability and control characteristics of the model in transition flight from hovering to level flight. Some of the flights were made with the flywheel operating at one-half speed and some at full speed to determine the effects of the jet-engine gyroscopic forces on the transition flight behavior of the model.

These flights were slow constant-altitude transitions covering a speed range from about 0 to 50 knots, which corresponds to full-scale airspeeds of 0 to 110 knots. Since small adjustments or corrections in the tunnel airspeed could not be made readily, the pitch pilot and the power operator had to continually make adjustments in order to hold the model in the center of the test section. Flights were also made in which the airspeed was held constant at intermediate speeds so that the stability and control characteristics at a particular speed could be studied.

In order to study the stability and control characteristics of the model in rapid transitions, flight tests were also made on the control-line facility. This part of the investigation was limited to a study of longitudinal stability and control since the model is restrained in the lateral degrees of freedom by the control line.

Hovering flight tests.- Hovering flight tests were made with the model hovering at heights of 15 to 20 feet above the ground to determine the basic stability and controllability of the model. These tests were made both indoors in still air and outdoors in moderately rough air. The same type of setup and techniques were used to fly the model in both the indoor tests and the outdoor tests, with the exception that compressed air was used for the indoor tests and hydrogen peroxide was used for the outdoor tests. The tests included a study of the effect of engine gyroscopic moments on the hovering flight behavior of the model with the flywheel running at full speed and one-half speed. In order to determine whether a simple cross coupling of the controls would effectively cancel the effect of the gyroscopic precessional moment of the jet engine for practical purposes, flights were made with the hinge lines of the swiveling nozzle rotated various amounts about

the fuselage axis. Tests were also made to determine the effects of damping in pitch and yaw on the hovering flight behavior of the model with and without the jet-engine gyroscopic forces represented.

Take-off and landing flight tests.- The take-offs from a horizontal wire were made by rapidly increasing the thrust until the model had climbed clear of the horizontal wire. The power operator then adjusted the thrust for either hovering flight or a transition from hovering to forward flight. For the landing tests the power operator first adjusted the thrust so that the model would hover near the wire. Then the thrust was reduced so that the model descended slowly and the pilot maneuvered the model to engage the wire with the landing hook. At this point the thrust was reduced as quickly as possible, and the model settled down on the wire.

Force tests.- Some preliminary force tests were made in the free-flight tunnel in an effort to determine some of the stability and control characteristics of the model in transition flight. The tests were made with power on by using compressed air to supply the necessary thrust to balance the drag along the wind axis for the zero sideslip condition.

RESULTS AND DISCUSSION

A motion-picture film supplement has been prepared and is available on loan. A request card form and a description of the film will be found at the back of this paper, on the page immediately preceding the abstract and index pages.

Hovering Flight

The model could be flown smoothly and easily in hovering flight without the aid of any artificial stabilization when the gyroscopic effects of the jet engine were not represented. The jet-reaction controls provided good controllability, and the model could be moved fairly rapidly from one position to another and restored quickly to a steady-flight condition. The motions of the model in pitch and yaw were very steady. Since the stability was not studied in detail, it is not known whether the model had unstable pitching and yawing oscillations such as had been experienced previously with propeller-driven models of the tail-sitter type of VTOL airplanes. (See, for example, ref. 2.) It was clear, however, that the model did not tend to start an oscillation as quickly as did the propeller-driven models and was, consequently, easier for the pilots to fly. The rolling motions, as would



be expected, seemed about neutrally stable. These flights without the flywheel running to represent the engine gyroscopic effects were intended to provide basic research information on a configuration of the Ryan X-13 VTOL type of airplane. In this condition the model would represent an airplane powered by two or more oppositely rotating engines or by a split-compressor engine with oppositely rotating compressor sections which would give a very low net gyroscopic effect.

Attempts to hover the model with the flywheel running at full speed to correctly simulate the gyroscopic effects of the jet engine of the Ryan X-13 VTOL airplane were unsuccessful because of the violent motion resulting from the coupling of the yawing and pitching motions. The pilots were unable to control the model for any appreciable period of time and considered it completely uncontrollable.

Cross coupling the pitch and yaw controls by rotating the gimbal rings of the swiveling nozzle about the center line of the ejector tube proved to be an unsuccessful method of reducing the troubles caused by the gyroscopic cross coupling because the coupling resulting from motions other than those induced by the controls was not counteracted at all. The flights generally started off well but soon ended with the loss of control of the model by the pilots. Of the angles obtained by rotating the gimbal rings (from 0° to 45° clockwise, looking at the rear of the model) angles between 15° and 30° seemed to be the best with the flywheel rotating in a counterclockwise direction as viewed from the rear. Even these angles, however, barely afforded any noticeable improvement in the flight behavior of the model.

The use of pitch and yaw dampers greatly improved the hovering flight behavior of the model both with and without the gyroscopic effects of the jet engine simulated. In fact, the pilots were able to fly the model for long periods of time in still air without giving any control, even with the gyroscopic effects of the jet engine fully simulated.

The gyroscopic moments of a future tactical airplane of the general type represented by the X-13 airplane would be much less than those of the X-13 itself because the tactical airplane would be powered by an advanced afterburning engine of lower specific weight than the relatively old nonafterburning Rolls Royce Avon engine used in the X-13. Flight tests were, therefore, made with the flywheel rotating at one-half speed in order to represent approximately the gyroscopic moments of a turbojet engine such as might be used in a tactical airplane of this type. In these tests the model could be flown for short periods of time without any artificial stabilization, but the flights generally ended with the model getting out of control. The flights usually started with the model flying fairly smoothly and became progressively rougher as the



pilots gave corrective control or tried to maneuver the model. The pilots described the flight behavior of the model as being similar to hovering in gusty air, with little or no damping in pitch and yaw in that the model received repeated and unexpected disturbances about one axis as a result of motion about another axis.

Take-Offs and Landings

Take-offs from and landings on a horizontal wire were made on the control-line facility, where the model is restrained in the lateral degrees of freedom. These tests were made without artificial stabilization and without the gyroscopic effects of the jet engine simulated. Under these conditions take-offs and landings were easy to make. Since in the hovering tests the model flew more smoothly with the yaw and pitch dampers operating, even with the gyroscopic forces of the jet engine simulated, it would be expected that the take-offs and landings would be even easier to perform with the engine gyroscopic moments simulated and with artificial stabilization; this condition more closely approximates the flight condition of the full-scale airplane.

Transition Flight

Longitudinal characteristics.- Transitions from hovering to normal forward flight and back to hovering flight could be made smoothly and easily in the full-scale tunnel, and the model seemed to have stability of angle of attack over most of the speed range. At times the model would fly "hands off" in pitch for reasonably long periods of time when it was trimmed correctly and the airspeed was not being changed. These flights in the full-scale tunnel represented slow, constant-altitude transitions and covered a range of angles of attack from about 20° to 90° . For these tests the model was equipped with pitch and yaw dampers which operated the swiveling nozzle. The design of the control system in the model would not permit the jet-reaction pitch control to be switched out of the pitch-control system, so the jet controls were used throughout the transition. The elevons, however, could be switched in or out of the pitch-control system at will. It was found that the swiveling nozzle provided adequate pitch control throughout the transition, so the elevons were not generally used for control although they were generally trimmed up 10° to provide most of the trim required when the model was in normal forward flight at about a 20° angle of attack after the transition.

The model responded quickly to any adjustments in thrust and could be flown very smoothly and steadily. There was, however, a large and abrupt change in the thrust required for level flight between angles of attack of about 20° and 45° . This observation is further substantiated

by the data of figure 11 which shows a plot of thrust and angle of attack required for trimmed flight against forward speed as computed from some preliminary force-test data for a model weight of 40 pounds.

Additional flights were made on the control-line facility to study the longitudinal stability and control of the model in rapid constant-altitude transitions over a range of angles of attack from about 20° to 90° . The flight behavior of the model in the rapid transitions was about the same as in the slow transitions in that the model was easy to control in pitch by using the jet-reaction control. The elevons were set to trim the model at an angle of attack of about 20° and were not used to control the model. Thrust control was somewhat more difficult than for the slow transitions because the model went more rapidly through the angle-of-attack range from 20° to 45° where the large changes occurred in the thrust required.

Lateral characteristics.- The lateral stability and control characteristics of the model were generally satisfactory, and the transition could be made smoothly and easily throughout the angle-of-attack range. As pointed out previously, all of the transitions were made with a yaw damper operating the main jet nozzle because, in the hovering tests, it was found that artificial damping was required to reduce the effects of the engine gyroscopic moments. The X-13 model was not flown without the dampers; therefore, no information was obtained on the behavior of an airplane of the same general configuration but with counterrotating engines or split-compressor engines with oppositely rotating compressor sections which would give practically no net gyroscopic effects. The behavior of a somewhat similar model under these conditions was reported in reference 3, however, and showed that a certain amount of automatic stabilization was very desirable in the transition range.

The one undesirable lateral stability characteristic of the model was that at angles of attack between approximately 25° to 45° the model tended to fly in a rolled and sideslipped attitude. This did not appear to be a dangerous condition, and the pilot had no difficulty in keeping the model in the center of the test section. In fact, the model would fly "hands off" for long periods of time when the airspeed and angle of attack were not being varied. The roll pilot found that a large amount of roll control, approximately the maximum control available on the airplane, was required to restore the model to zero bank once it had gotten into this trimmed rolled and sideslipped attitude. Some preliminary force tests were made, and the results are presented in figure 12. In order to approximate the actual flight conditions in the tunnel, the tests were made with the elevons trimmed up -10° and the thrust adjusted to give zero drag along the wind axis for the zero sideslip condition.

The data from these force tests which covered a range of angle of attack from 20° to 50° show that the model is directionally unstable at angles of sideslip up to 20° or 30° throughout this angle-of-attack range except at $\alpha = 20^\circ$ where the model is slightly stable. The effective dihedral varies from stable at an angle of attack of 20° to unstable at angles between 25° and 45° and to about neutral at 50° . The data indicate that the model might have a tendency to trim in roll and yaw at large angles of sideslip, but this result is not clear from this presentation of the data. In order to bring out this characteristic more clearly, the data have been recomputed and plotted in figure 13 to show the variation of yawing- and rolling-moment coefficient with angle of bank about the body axis. If the model simply rolls about the body axis, an angle of sideslip equal to $i_f \sin \phi$ is introduced, and the angle of attack becomes equal to $i_f \cos \phi$. Figure 13 was obtained by the use of these simple angular relations and interpolation from the data of figure 12. The data of figure 13 clearly show that the model was unstable at small angles of bank and had stable trim points at high angles of bank. A relatively small amount of roll- or yaw-control deflection would make both the yawing- and rolling-moment curves trim to zero moment at the same angle of bank; therefore, a stable trimmed condition at about a 45° bank similar to that encountered in the flight tests would be indicated. The model can perform a simple bank such as this without much change in its angle of pitch to compensate for a loss in lift because of its large side force which supplies the vertical force required to replace that lost by the wing.

SUMMARY OF RESULTS

The results of a flight investigation of the stability and control characteristics of a 1/5-scale flying model of the Ryan X-13 jet VTOL airplane can be summarized as follows:

1. In hovering flight the model could be flown smoothly and easily without any automatic stabilization devices when the gyroscopic effects of the jet engine were not represented. The jet-reaction controls provided good controllability, and the model could be moved fairly rapidly from one position to another and restored quickly to a steady-flight condition.
2. When the engine gyroscopic effects were simulated, the model could not be controlled in hovering flight without artificial stabilization because of the strong gyroscopic coupling of the yawing and pitching motions. The use of pitch and yaw dampers made these motions completely stable and the model could then be controlled very easily.

3. If the gyroscopic effects of the turbojet engine were simulated at one-half true scale magnitude to represent an airplane with an engine of more advanced (lighter) design, the model could be flown without artificial stabilization for short periods of time but then went out of control.

4. In the transition tests, which were performed only with the automatic pitch and yaw dampers operating, it was found that the transition was very easy to perform either with or without the gyroscopic effects of the jet engine simulated, even though the model had a tendency to fly in a rolled and sideslipped attitude between angles of attack of approximately 25° and 45° . This sideslipping tendency resulted from the fact that the model was unstable in yaw and roll in this angle-of-attack range but had a stable trim point at large angles of bank and sideslip.

5. The swiveling nozzle on the main jet provided good yaw and pitch control through the entire speed range covered in the investigation.

Langley Aeronautical Laboratory,
National Advisory Committee for Aeronautics,
Langley Field, Va., August 19, 1958.

REFERENCES

1. Schade, Robert O.: Flight-Test Investigation on the Langley Control-Line Facility of a Model of a Propeller-Driven Tail-Sitter-Type Vertical-Take-Off Airplane With Delta Wing During Rapid Transitions. NACA TN 4070, 1957.
2. Kirby, Robert H.: Flight Investigation of the Stability and Control Characteristics of a Vertically Rising Airplane Research Model With Swept or Unswept Wings and X- or +-Tails. NACA TN 3812, 1956.
3. Lovell, Powell M., Jr., and Parlett, Lysle P.: Effects of Wing Position and Vertical-Tail Configuration on Stability and Control Characteristics of a Jet-Powered Delta-Wing Vertically Rising Airplane Model. NACA TN 3899, 1957.

TABLE I

GEOMETRIC CHARACTERISTICS OF MODEL

Wing (modified triangular plan form):

Sweepback, deg	60
Airfoil section	NACA 65A008
Aspect ratio	1.97
Area, sq in.	1,094.4
Span, in.	46.4
Mean aerodynamic chord, in.	29.1
Moment arm of roll nozzles, in.	24.375
Incidence, deg	4
Dihedral, deg	0

Overall length of model, in. 56.25

Vertical tail (modified triangular plan form):

Sweepback, deg	45
Airfoil section	NACA 65A012
Aspect ratio	1.76
Area, sq in.	270
Span, in.	22

Outboard fin:

Airfoil section	NACA 65A011
Area, each, sq in.	23.4
Area, total, sq in.	46.8
Aspect ratio	3.57
Span, in.	9.14
Root chord, in.	7.02
Tip chord, in.	3.07



TABLE II

MASS CHARACTERISTICS OF MODEL

Weight:	
Indoor tests with compressed-air power	31.73
Outdoor tests with hydrogen-peroxide rocket power	39.3
Center-of-gravity location:	
Distance from leading edge of M.A.C., percent M.A.C.	30.4
Inertia of model:	
Indoor tests:	
I_x , slug-ft ²	0.603
I_y , slug-ft ²	1.473
I_z , slug-ft ²	1.510
Outdoor tests:	
I_x , slug-ft ²	0.603
I_y , slug-ft ²	1.784
I_z , slug-ft ²	1.821

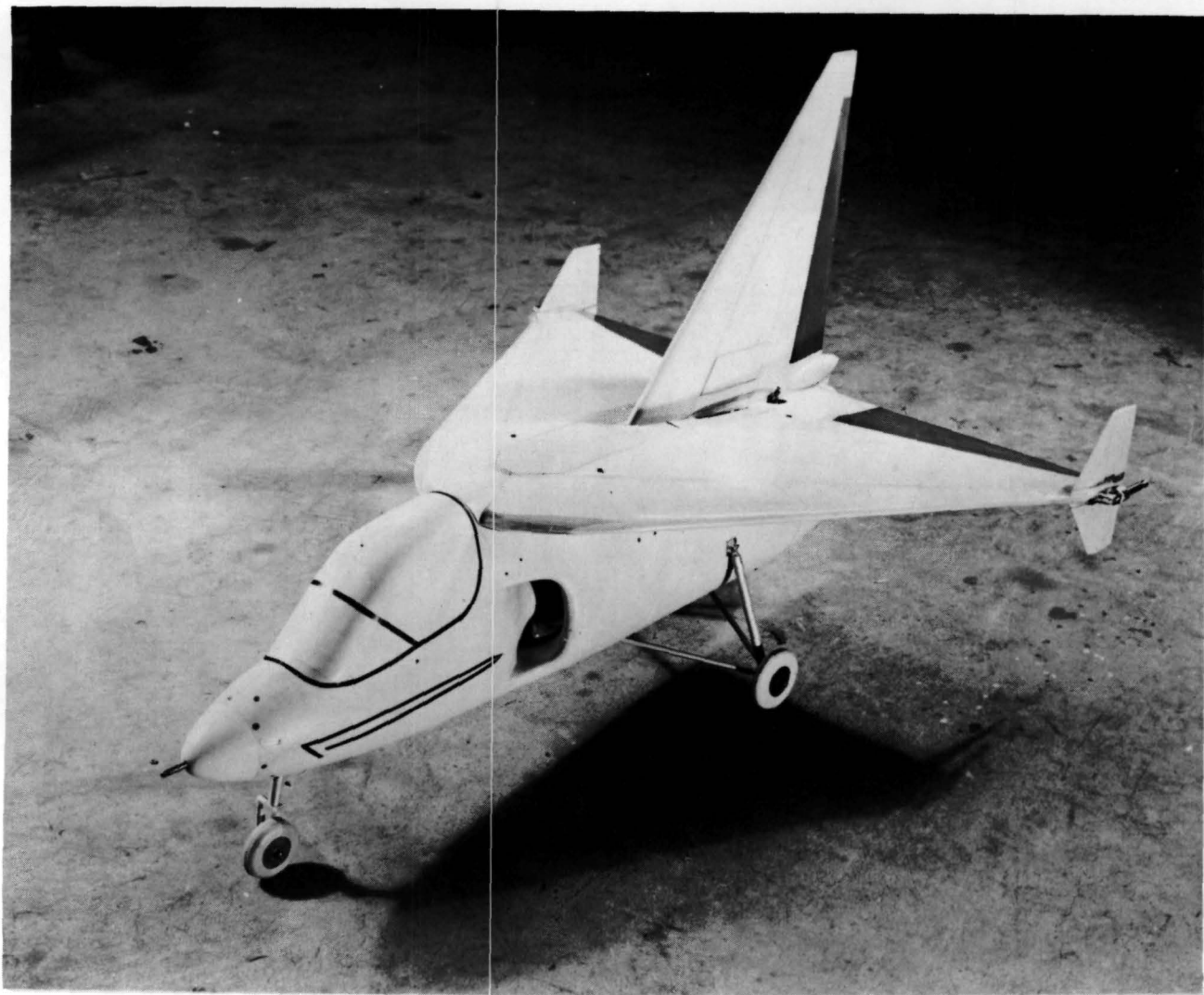

SECRET

Figure 1.- Three-quarter front view of the 1/5-scale model of the Ryan X-13 VTOL airplane. L-94531

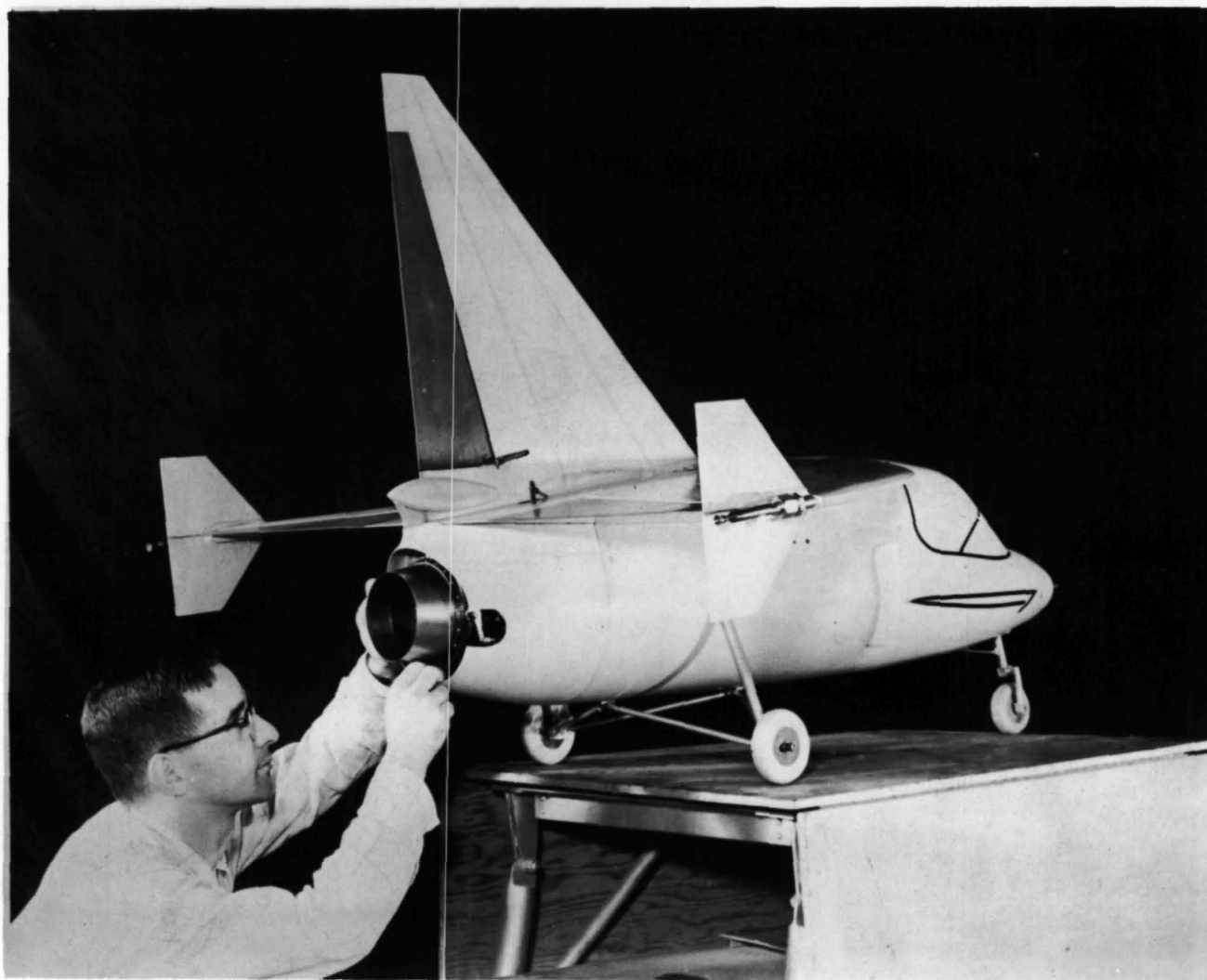

Figure 2.- Three-quarter rear view of the 1/5-scale model of the Ryan X-13 VTOL airplane.

L-94532

REF ID: A58100

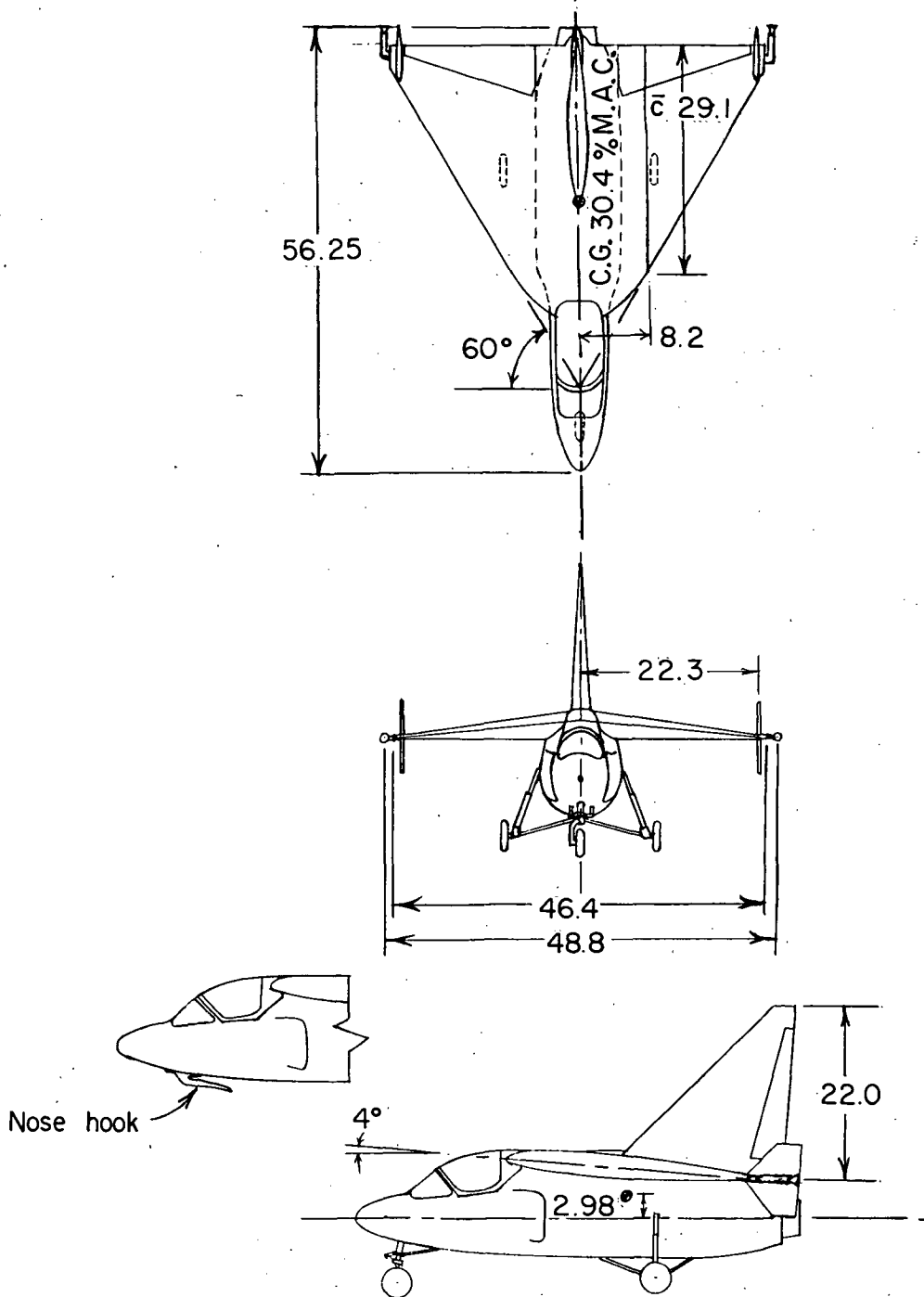

Figure 3.- Three-view sketch of the model used in the tests. All dimensions are in inches.

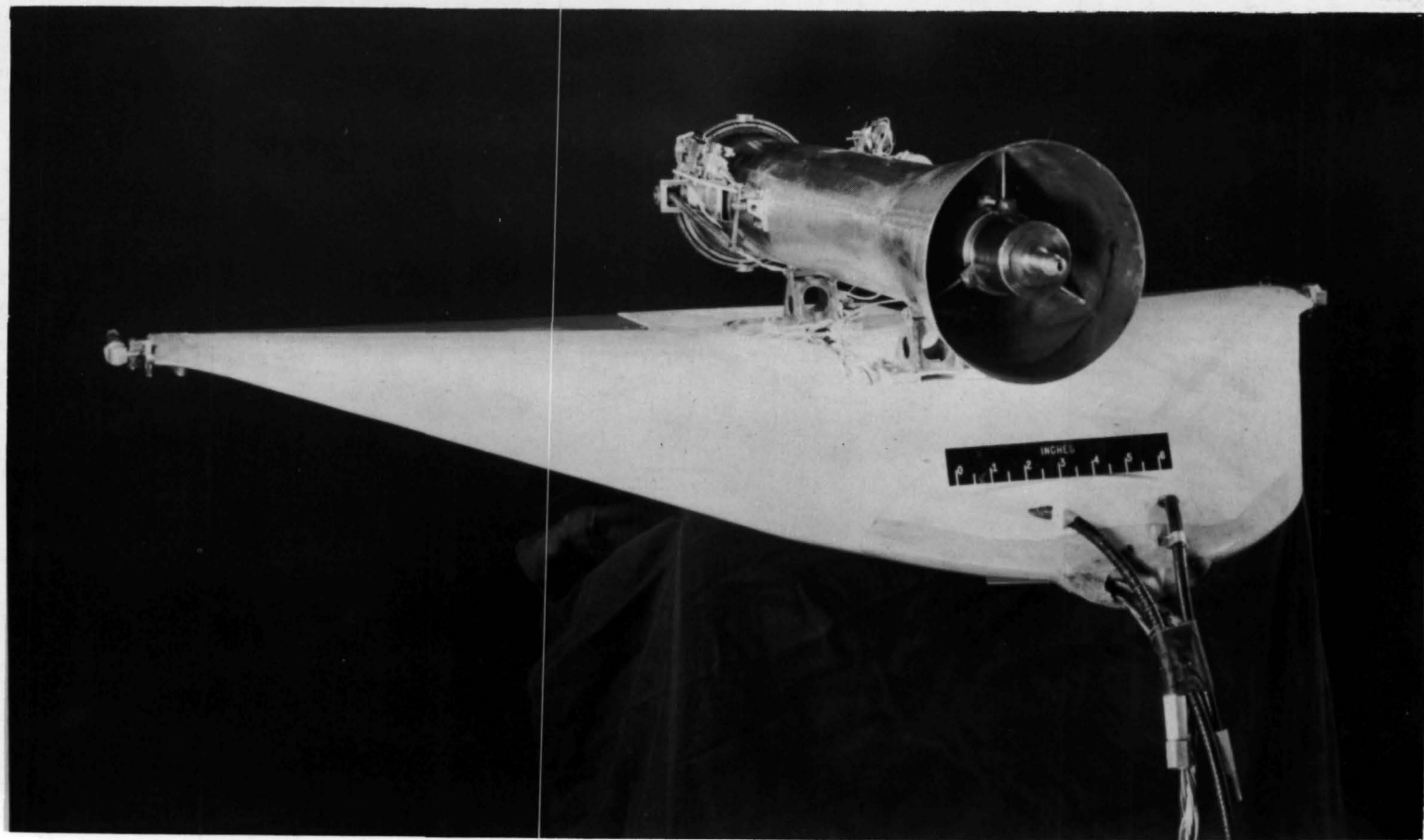
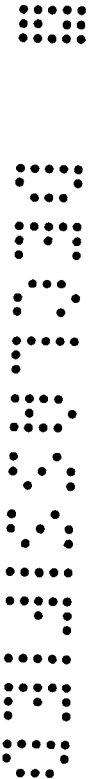
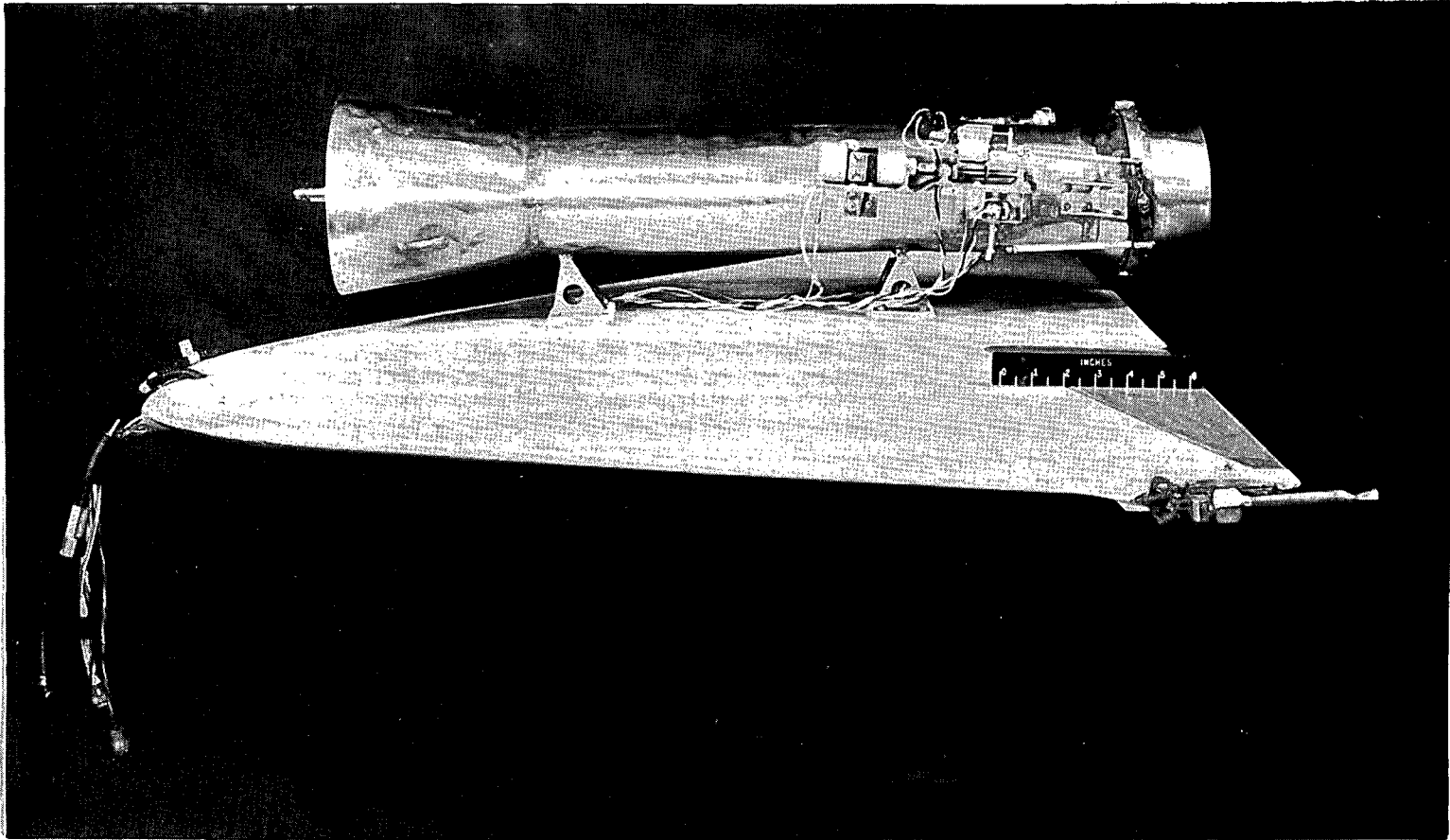

Figure 4.- Three-quarter front view of the hydrogen peroxide power plant used in the $1/5$ -scale model of the Ryan X-13 VTOL airplane.

L-94253



L-94254

Figure 5.- Side view of the hydrogen peroxide power plant used in the 1/5-scale model of the Ryan X-13 VTOL airplane.

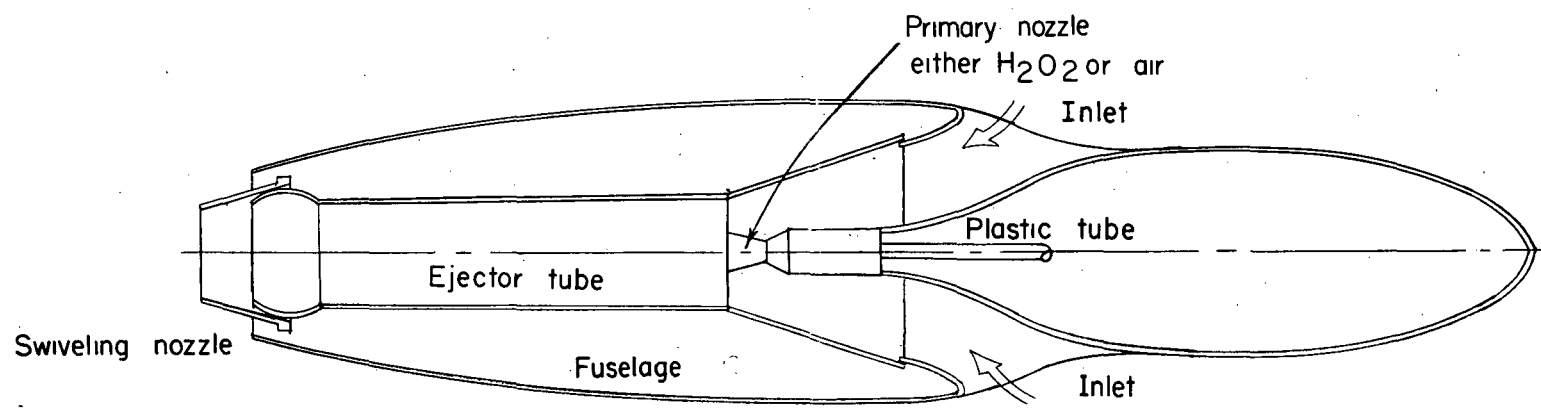

Figure 6.- Sketch of rocket motor installation inside the model.

SECRET

SECRET

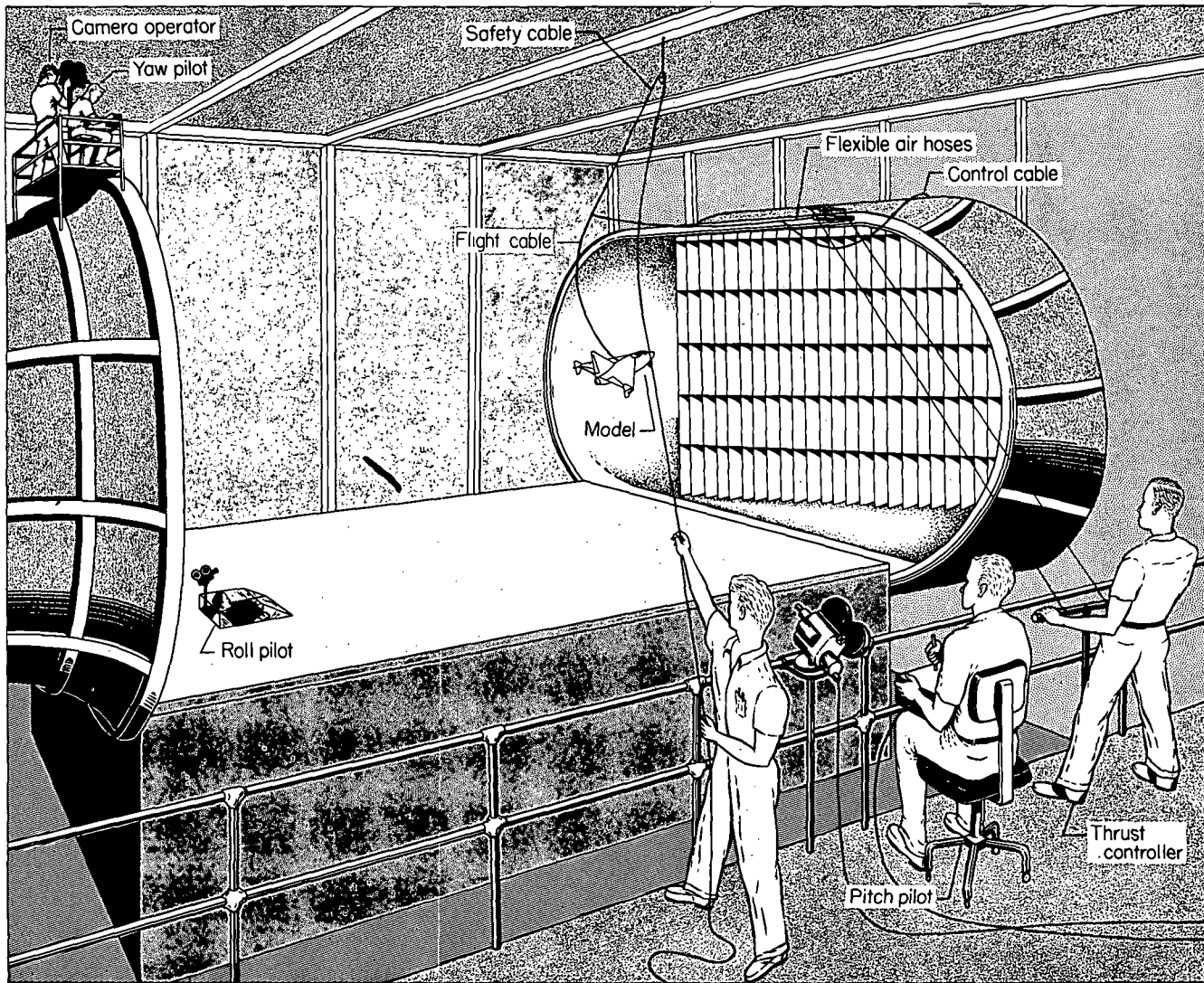

Figure 7.- Test setup for flight tests in the Langley full-scale tunnel.

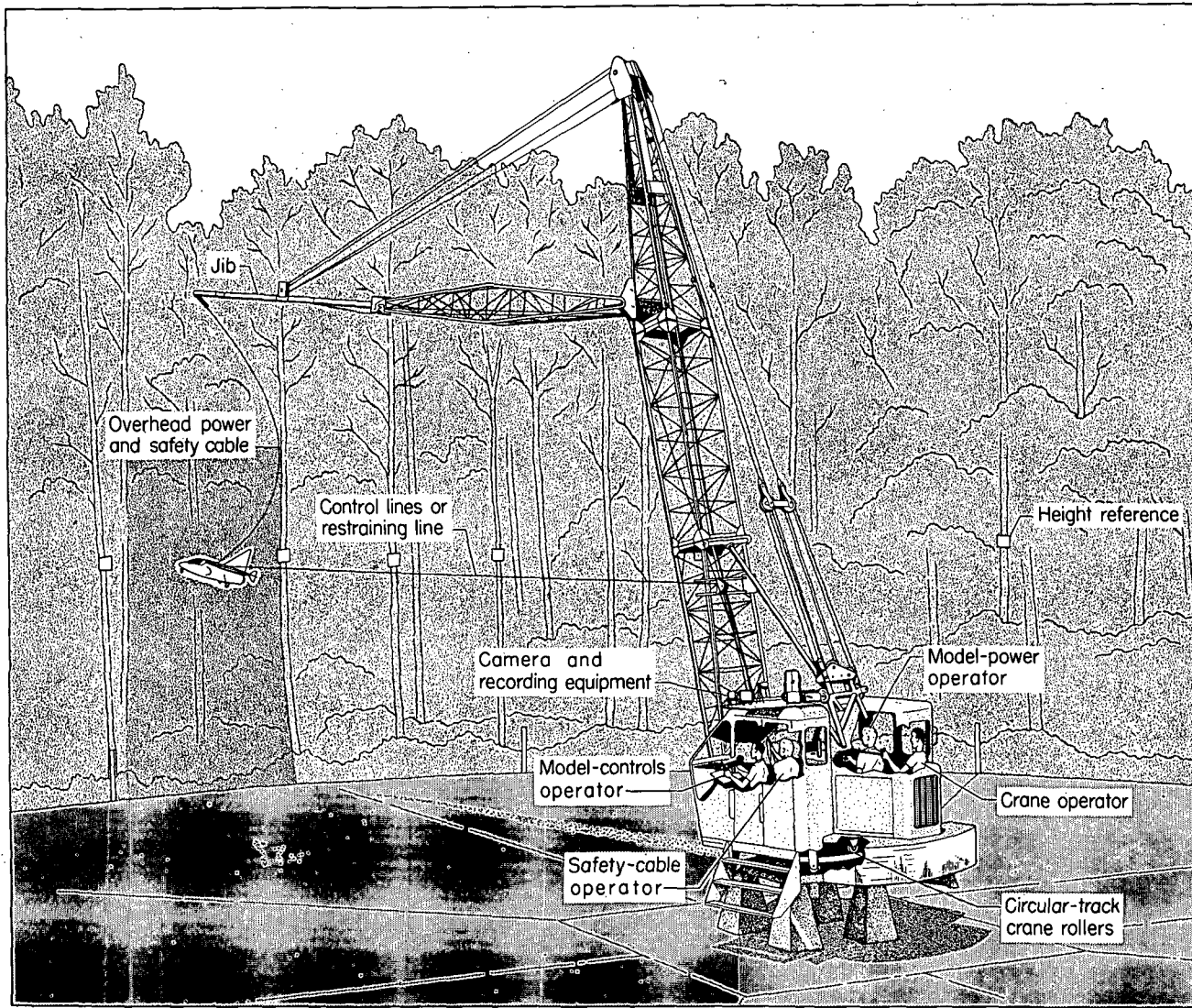
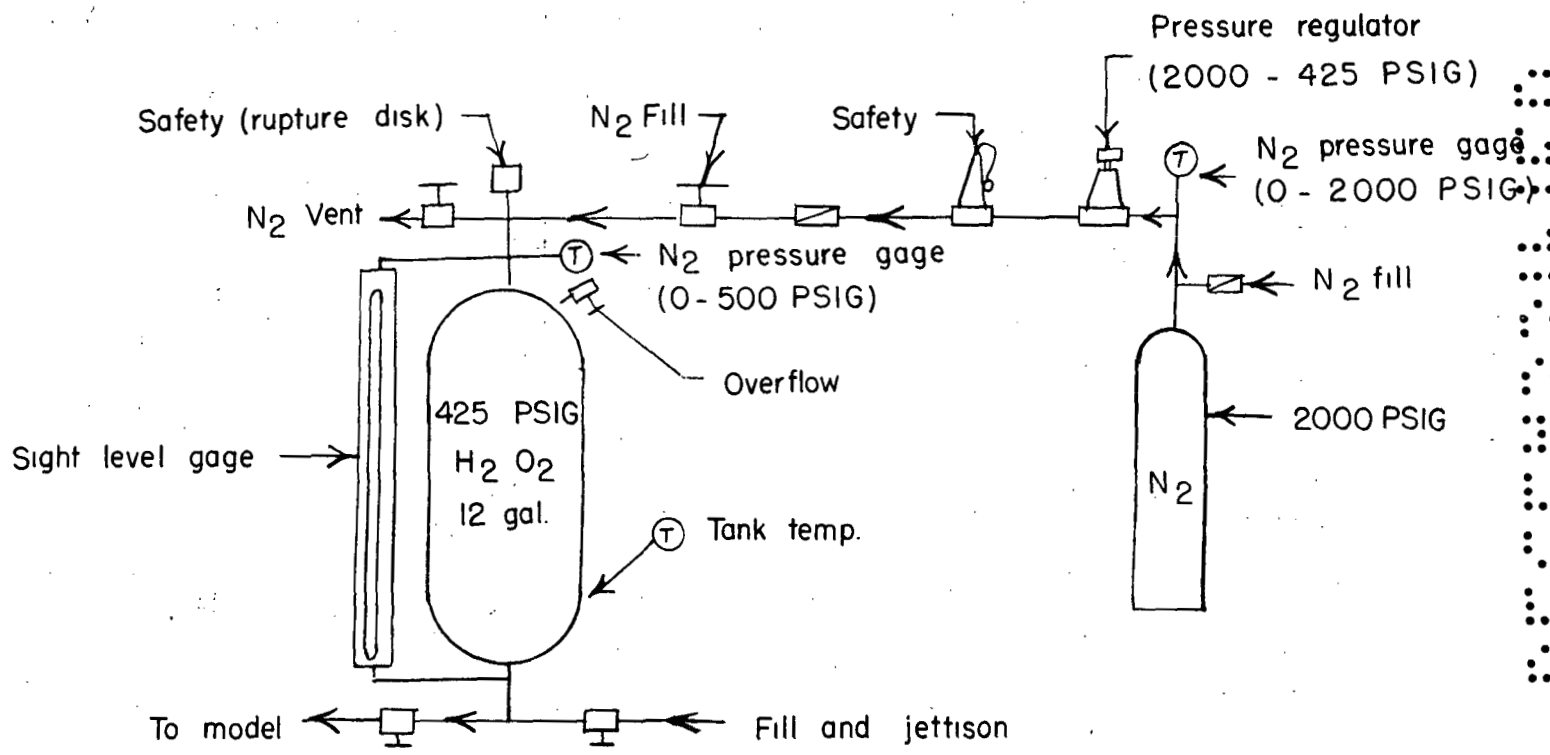

Figure 8.- The Langley control-line facility.





Figure 9.- Equipment for handling hydrogen peroxide. L-94280





-  Hand operated valves (gate or needle type)
-  Check valves
-  Gage

Figure 10.- Simplified schematic of hydrogen peroxide pressurizing equipment.

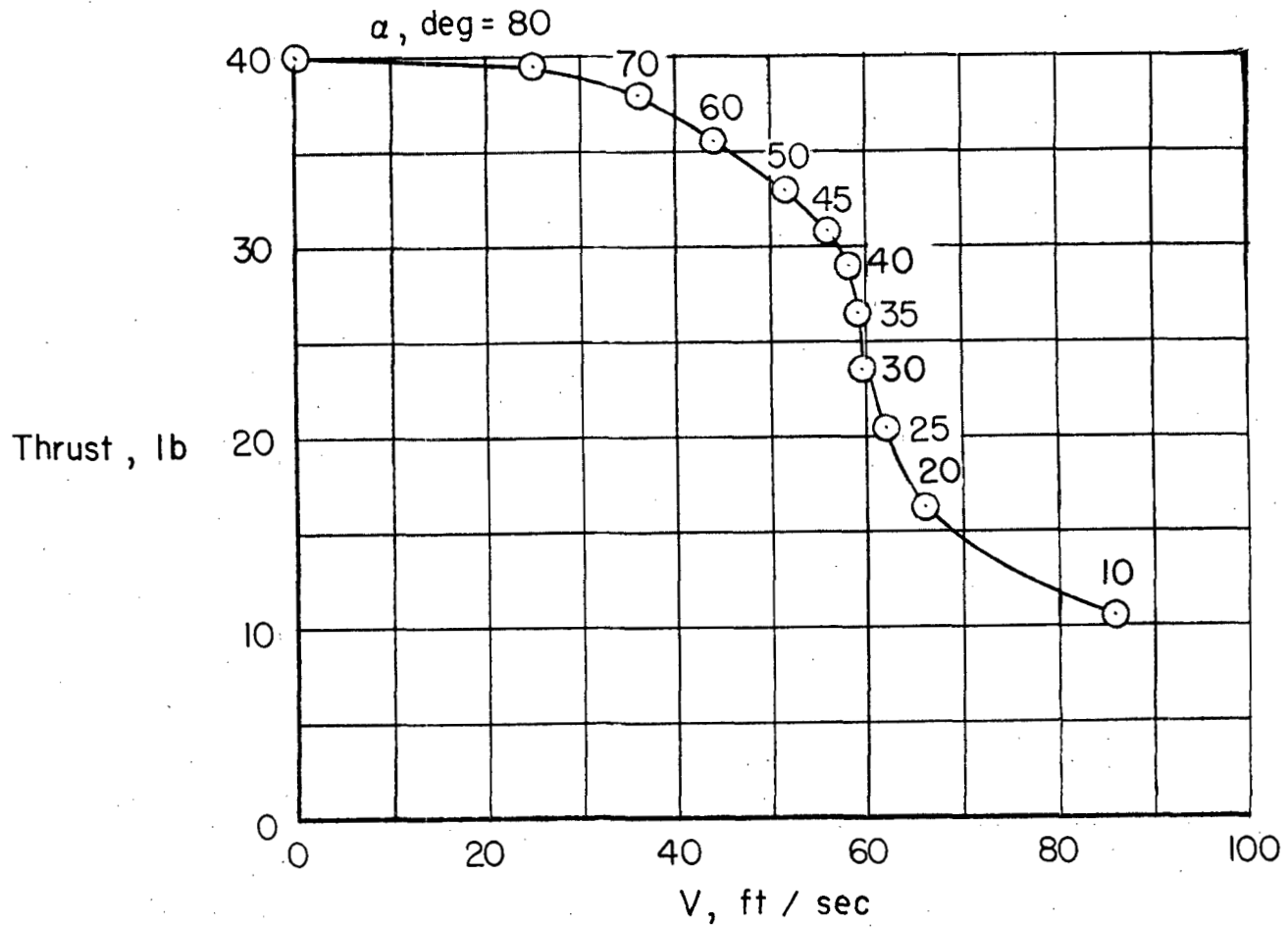

Figure 11.- Angle of attack and thrust required against airspeed for 1/5-scale model Ryan X-13 VTOL airplane.

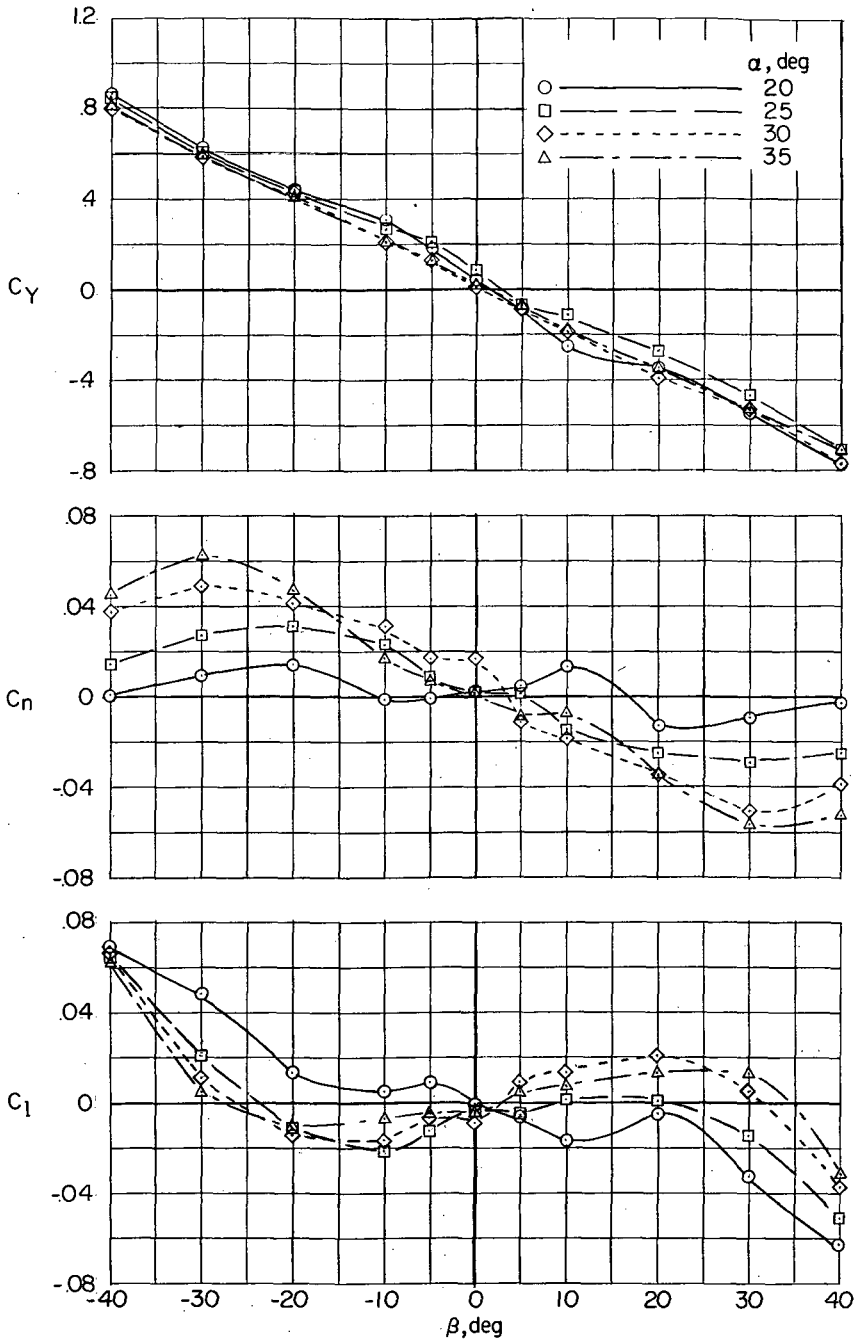

Figure 12.- Variation of static lateral stability characteristics with angle of sideslip for $\delta_e = -10^\circ$ and $\delta_a = 0^\circ$. Referred to body axis. Power on. $\phi = 0^\circ$.

DECLASSIFIED

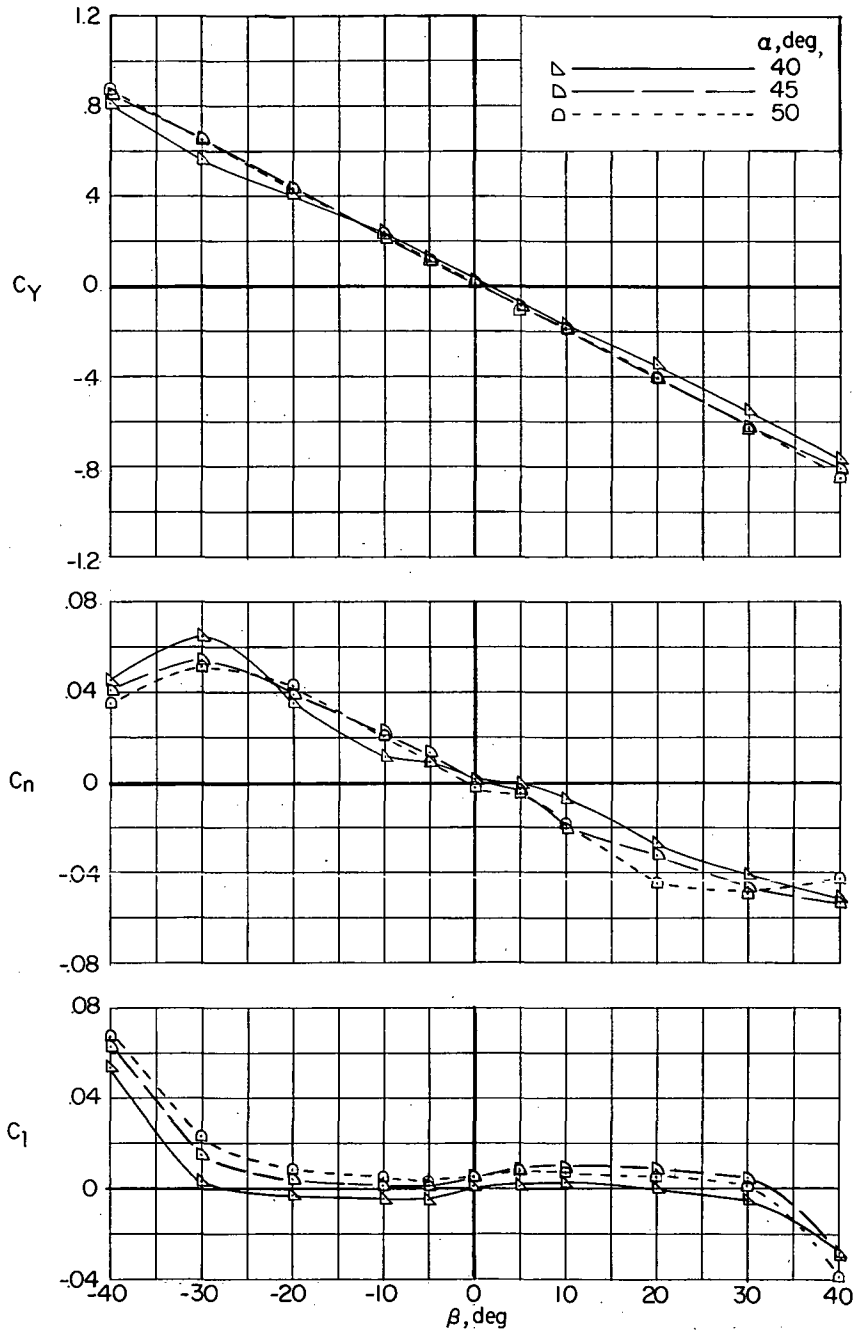

Figure 12.- Concluded.

CONFIDENTIAL

CONFIDENTIAL

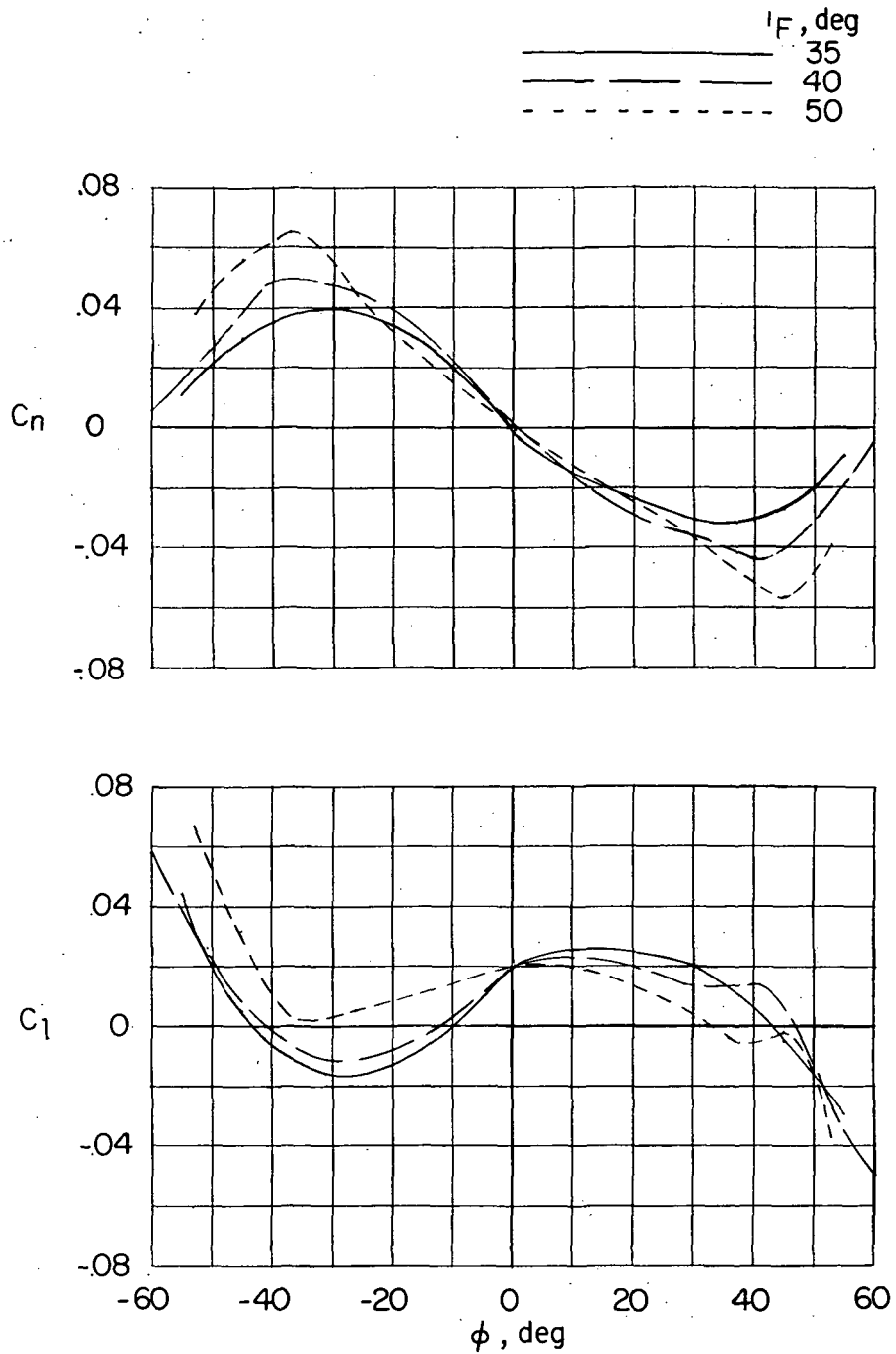

Figure 13.- Variation of C_l and C_n with ϕ about the body axis for several angles of attack. $\delta_e = -10^\circ$, $\delta_a = 0^\circ$.

HOVERING AND TRANSITION FLIGHT TESTS OF A 1/5 SCALE

MODEL OF THE RYAN X-13 VTOL AIRPLANE

COORD. NO. AF-199

Charles C. Smith, Jr.

Charles C. Smith, Jr.

Approved:

Thomas A. Harris

Thomas A. Harris
Chief of Stability Research Division
Langley Aeronautical Laboratory

rh
(10/19/58)

DECLASSIFIED

HOVERING AND TRANSITION FLIGHT TESTS OF A 1/5-SCALE
MODEL OF THE RYAN X-13 VTOL AIRPLANE*

COORD. NO. AF-199

By Charles C. Smith, Jr.

ABSTRACT

This vertical-attitude airplane, which is powered by a single turbo-jet engine, has a triangular wing mounted high on the fuselage with a triangular tail on top of the wing and has no horizontal tail. The airplane has conventional elevon and rudder controls for use in normal flight and has jet-reaction controls for use in hovering and at low air-speeds. The investigation included stability and control flight tests of the basic model configuration and also included a study of the effects of engine gyroscopic moments on stability and control.

INDEX HEADINGS

Stability, Dynamic	1.8.1.2
Control, Longitudinal	1.8.2.1
Control, Lateral	1.8.2.2
Control, Directional	1.8.2.3
Flying Qualities	1.8.5
Mass and Gyroscopic Problems	1.8.6
Stabilization, Automatic	1.8.8

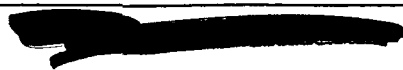
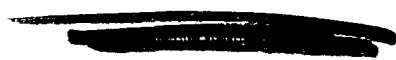

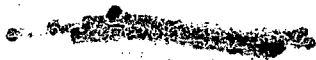
03 10 20 30 40 50 60



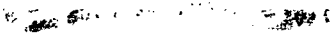
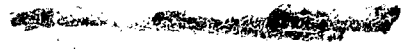

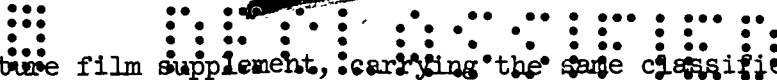
A motion-picture film supplement, carrying the same classification as the report, is available on loan. Requests will be filled in the order received. You will be notified of the approximate date scheduled.

The film (16mm, 15 min., color and black and white, silent) shows flight tests of the model in take-offs and landings, in hovering flight, and during the transition from hovering to normal forward flight.

Requests for the film should be addressed to the

Division of Research Information
National Advisory Committee for Aeronautics
1512 H Street, N. W.
Washington 25, D. C.

NOTE: It will expedite the handling of requests for this classified film if application for the loan is made by the individual to whom this copy of the report was issued. In line with established policy, classified material is sent only to previously designated individuals. Your cooperation in this regard will be appreciated.



CUT

Date _____

Please send, on loan, copy of film supplement to RM SL58H29

Name of organization _____

Street number _____

City and State _____

Attention:* Mr. _____

Title _____

*To whom copy No. ___ of the RM was issued

03712201030



Place
Stamp
Here

Division of Research Information
National Advisory Committee for Aeronautics
1512 H Street, N. W.
Washington 25, D. C