

Hydrogen Peroxide Propulsion for Smaller Satellites

John C. Whitehead
Lawrence Livermore National Laboratory
L-43, PO Box 808
Livermore, CA 94551
925-423-4847
jcw@llnl.gov

Abstract. As satellite designs shrink, providing maneuvering and control capability falls outside the realm of available propulsion technology. While cold gas has been used on the smallest satellites, hydrogen peroxide propellant is suggested as the next step in performance and cost before hydrazine. Minimal toxicity and a small scale enable benchtop propellant preparation and development testing. Progress toward low-cost thrusters and self-pressurizing tank systems is described.

Introduction

Conventional satellite propulsion technology is highly refined and continues to evolve. The needs of spacecraft massing hundreds to thousands of kilograms are well met. Often, flight systems aren't even functionally tested. Trust can be placed in familiar system concepts and the selection of flight-proven component designs. Unfortunately, most such components are too large and heavy for smaller spacecraft massing tens of kilograms. The latter have therefore been limited to nitrogen propulsion. This cold gas yields only 50 to 70 s Isp, requires heavy tanks, and has a poor density (e.g. $\sim 400 \text{ kg/m}^3$ at 5000 psi). The wide gaps in cost and performance between nitrogen and hydrazine suggests consideration of intermediate options.

In recent years there has been renewed interest in using high test hydrogen peroxide (HTP) for rocketry on all scales. It is most attractive for new applications where existing capability cannot directly compete. This is consistent with using HTP on satellites in the 5-50 kg range. As a monopropellant, HTP offers a high storage density ($>1300 \text{ kg/m}^3$) and a vacuum specific impulse (Isp) near 150 s. While this is well below hydrazine at 230 s, alcohol or hydrocarbon in combination with HTP can raise Isp into the 250 to 300 range.

Cost is a key issue, because HTP propulsion is only worth pursuing if it's cheaper than scaling down conventional liquid technology. This is likely, considering how vapor toxicity impacts development, qualification, and launch operations. For example, relatively few facilities exist for rocket testing with toxic propellants, and their number has been dwindling. In contrast, builders of small satellites could invest in their own HTP capability.

The toxicity argument is stronger for development of unusual system concepts. Such efforts can benefit greatly from affordable frequent testing. Broken hardware with a propellant spill should be accepted as a routine event, just as developmental software crashes are. While propellant toxicity has helped to establish a conventional methodology which encourages evolutionary advances, it is possible that smaller satellites can benefit from major changes.

The work reported here is part of a greater research program toward new space technologies on a small scale. Complete microsatellite prototypes are being tested.¹ Related topics of interest include miniature pump fed rocket engines for the most challenging maneuvers, such as Mars departure and round trips to the moon on an affordable scale.² Such a capability would also be ideal for putting smaller exploration spacecraft onto escape trajectories. The focus of this paper is on implementing HTP propulsion using low cost materials and methods. The performance criterion of interest here is to significantly exceed the capability of stored nitrogen. Careful consideration of maneuvering needs can help to avoid unnecessary requirements which drive cost.

Propulsion Requirements

In an ideal world, it would be possible to treat satellite propulsion systems as computer peripherals. However, there are unique characteristics not shared with most other satellite subsystems. For example, propellant is often the most massive item, and its expenditure can potentially shift the satellite's center of mass. Thrust vectors used for velocity change maneuvers must of course pass through the mass center. While thermal considerations are inherent to the integration of most subsystems, they are more challenging for propulsion. Engines generate the highest

temperatures on a spacecraft, while propellant often has a narrower acceptable temperature range than other items. For all these reasons, maneuvering needs can have a major impact on a satellite's design.

Characteristics of electronics subsystems which are taken for granted are not inherent to propulsion. These include indefinite storage on orbit, rapid on/off responses, and the capability to subsequently endure quiescent periods of arbitrary duration. From a propulsion engineering perspective, a definition of mission needs includes a timeline showing when each thruster must operate and approximately how long. This information may be essential, but in any case reduces engineering difficulty and cost. For example, propulsion hardware can be tested with low-cost data recording if millisecond timing is not critical to the mission.

Other cost drivers include the possible need for precise predictability of thrust and specific impulse. Traditionally, this enabled calculated velocity changes with pre-planned burn durations. Given modern instrumentation and onboard computational capabilities, it makes sense to integrate accelerometer outputs until the desired velocity change is achieved. Relaxed requirements would facilitate cost-effective custom development. Precise trimming of pressures and flows, as well as expensive testing in vacuum chambers, might be avoided. Vacuum thermal considerations would still need to be addressed.

The easiest propulsion timeline is to thrust continuously for only one maneuver, early in a satellite's life. In this case, the initial response and warmup time matters least. Detectable amounts of leakage before and after the maneuver would not impair functionality. Such a simple propulsion requirement may be challenging for other reasons, such as a high v . If required acceleration is high, the engine's size and thrust-to-weight ratio increase in importance.

The most difficult thrust timeline is tens of thousands or more short pulses separated by hours or minutes, over many years. Start and stop transients, as well as heat losses to hardware and fluid leakage, must be minimized or eliminated. This type of thrust duty cycle is typical of 3-axis attitude control.

A mission timeline of intermediate difficulty would have occasional propulsion operation. Examples include orbit changes, drag makeup, or occasional re-orienting of a spin stabilized satellite. Infrequent propulsion operation would also apply to satellites which have momentum wheels or those which use gravity gradient stabilization. Such missions would have short bursts of high propulsion

system activity. This is important because hot components would lose little heat during active periods. Hardware could be less sophisticated than for long term attitude control, so these missions may be good candidates for low-cost liquid propulsion.

Requirements Influence Thruster Design

The low thrust levels appropriate for orbit changing maneuvers of tiny satellites are similar to those used on large spacecraft for maintaining orientation and orbits. However, the available flight-proven thrusters in this class exist primarily for the latter purpose. Features such as electric preheaters and thermal isolation permit a high average specific impulse over many short pulses. Hardware mass and size are increased, which is acceptable for large satellites but could overwhelm smaller ones. The mass discrepancy is even more significant for electric propulsion. Arcjets and ion thrusters are very heavy relative to their thrust levels.

Operating lifetime requirements also affect mass and dimensions. In the case of monopropellant thrusters for example, including extra catalyst can increase life. An attitude control thruster may have cumulative operation of many hours. However, a satellite's tanks would be emptied in minutes by a large orbit change maneuver. Regarding leakage, series-redundant valves are used to ensure a tight shutoff after many cycles. The extra valve could be a burden to smaller satellites.

Figure 1 shows that flight-proven liquid thrusters do not necessarily scale down as would be desired for tiny propulsion systems. Large thrusters can typically lift 10 to 30 times their own weight, and this number increases to 100 for pump-fed launch vehicle engines. However, the smallest liquid thrusters can't even lift themselves.

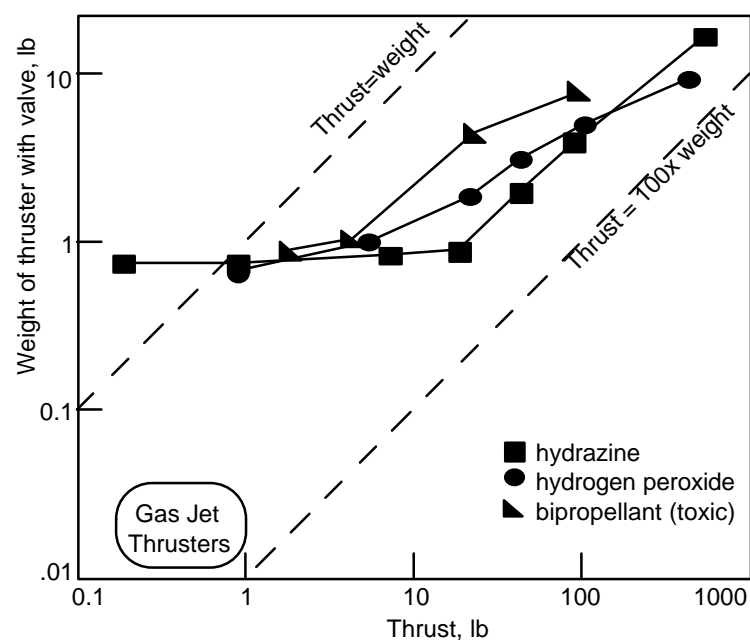

Figure 1. Satellite thrusters do not scale down easily.

Even if a small existing thruster is light enough to serve as a microsatellite's main maneuvering engine, selecting a set of 6 to 12 liquid attitude control thrusters for a 10 kg spacecraft is practically impossible. Therefore, tiny space vehicles have used cold gas for attitude control. As shown in Figure 1, gas thrusters exist with thrust-to-weight ratios as high as those of large space engines. They are simply a solenoid valve having a nozzle.

In addition to solving the thruster weight problem, gas jets have shorter pulse times than liquid thrusters. This is essential for continuous attitude control over long missions, as shown in the Appendix. As spacecraft are scaled down, shorter pulses can help to maintain the same pointing accuracy over a given lifetime.

While gas jets may appear to be a panacea for smaller satellites, stored gas occupies a relatively large volume and requires heavy tanks. State-of-the-art composite nitrogen tanks sized for smaller satellites weigh roughly as much as the nitrogen itself. In contrast, spacecraft liquid tanks carry up to 30 times their own mass in propellant. Considering both thrusters and tanks, it would be highly beneficial to carry propellant in liquid form, and then convert it to a gas to be distributed among a set of attitude control jets. This type of system has been implemented with hydrazine for short duration suborbital test flights.³

Hydrogen Peroxide Propellant

As a monopropellant, pure H_2O_2 yields oxygen and superheated steam just above 1800 F in the absence of heat losses. Mixtures with water are more typically encountered, but solutions below 67% don't have enough energy to vaporize all the water. Piloted U.S. test vehicles circa 1960 used 90% HTP for attitude control, with an adiabatic decomposition temperature near 1400 F and 160 s steady state Isp.⁴ HTP at 82% makes the 1030 F gas which drives the main engine pumps on the Soyuz launch vehicle.⁵ The various dilutions exist because propellant cost increases with concentration, and temperature affects material properties. Aluminum alloys, for example, are useful to about 500 F. This would limit concentration to 70% if used adiabatically.

Preparation for Concentration and Purity

Hydrogen peroxide is commercially available over a wide range of concentrations, purities, and quantities. Unfortunately, this does not include small containers of HTP which are directly useable as a propellant. Large

drums of rocket grade HTP exist, but these may not be readily available (e.g. in the United States). Also, handling large quantities requires facility features and safety precautions which can be an unnecessary burden when only small amounts are needed.

For the present work, food grade 35% hydrogen peroxide is purchased in gallon polyethylene containers. It is first concentrated to 85% and then purified, using the apparatus shown in Figure 2. This variation of a previous method⁶ simplifies the apparatus and reduces glassware cleaning. Operation is automated, so only daily emptying and filling of vessels is required to yield 2 liters over a regular work week. Certainly the cost per liter is high, but the total is still affordable on a small scale.



Figure 2. Evaporative concentration and distillation.

First, a pair of liter size beakers on hot plates are used to preferentially evaporate water during a timer-controlled period of 18 hours. The volume in each beaker is quartered to 250 cc, or about 30% of the initial mass. One fourth of the initial H_2O_2 molecules are lost as vapor. The loss rate increases with concentration, so 85% is a practical limit for this evaporative process.

The setup at left is an off-the-shelf rotary evaporator. The 85% solution having ~80 ppm concentrated impurities is heated in 750 cc batches by a water bath at 50 C. The sealed glassware is held internally below 10 mm Hg, which provides for rapid evaporation over a period of 3-4 hours. Condensate drips into the flask at lower left with <5% loss.

A dual water aspirator is visible behind the glassware. One port pulls the vacuum, while the other circulates water through a chiller, the condenser coils, and the aspirator bath itself. A temperature just above freezing improves both condensation and the aspirator's vacuum capability.

Vapors which escape the condenser are rendered harmless by dilution.

Pure hydrogen peroxide (100% HTP) is much denser than water (1.45 at 20 C), so a floating glass hydrometer (range 1.2-1.4) readily indicates concentration to within 1%. Both the purchased product and the distilled HTP were analyzed for impurities, as shown in Table 1. This included plasma emission spectroscopy, ion chromatography, and a total organic carbon (TOC) analysis. Note that phosphate and tin are stabilizers, and they are apparently introduced as salts of potassium and sodium.

Table 1. Analysis of Hydrogen Peroxide Solutions

<u>Constituent</u>	<u>Purchased</u>	<u>Conc. & Distilled</u>
H ₂ O ₂	35% by mass	85
Ca	.01 mg/kg	.03
K	2.6	<0.1
Na	1.2	<0.1
P	3.9	<0.5
S	.04	.05
Sn	3.7	.08
Ammonium	1.13 mg/l	<0.4
Nitrate	4.7	5.9
Phosphate	7.4	<.02
Sulfate	0.4	1.6
TOC	<0.1 mg/kg	<0.1

Not detected at thresholds between .01-0.1 ppm:

Al Ag Ba Br Cl Cu Cr F Fe Mg Mn Ni Si Zn

Not detected at threshold 0.5 ppm: Pb

Propellant Hazards

H₂O₂ decays to oxygen and water, so there aren't long term toxicity or environmental concerns. The most prevalent hazard of HTP is skin contact with droplets too small to notice. This temporarily causes benign but painful bleached spots which should be rinsed with cold water.

Similar effects on the eyes and lung tissue are more important to avoid. Fortunately, the vapor pressure is extremely low (2 mm Hg at 20 C). Benchtop ventilation readily keeps concentrations below the 1 ppm breathing limit (OSHA TLV). HTP is poured between open containers, over secondary containment trays. In contrast, N₂O₄ and N₂H₄ must always be contained within sealed systems, and a special breathing apparatus is often used. This is due to their much higher vapor pressures and a 0.1 ppm breathing limit for the latter.

Water dilution of HTP spills renders them nonhazardous. Regarding protective clothing requirements, cumbersome suits may increase the likelihood of spills. It seems appropriate to defer to personal preference when only small quantities are handled. For example, working with wet hands has been found to be a satisfactory alternative to gloves, which could even contain spills if they leak.

Although bulk liquid HTP does not propagate decomposition, highly concentrated vapor can be detonated by an ignition source.^{7&8} This potential hazard ultimately limits the throughput of the propellant preparation process described above. Calculations and measurements indicate a very high degree of safety for the actual production rates. In Figure 2, air is drawn into the horizontal exhaust slots behind the apparatus at 100 cfm across 6 feet of benchtop. Vapor concentrations below 10 ppm were measured directly above the concentrating beakers.

Disposal of small quantities after dilution has no environmental consequences, although this practice conflicts with the strictest interpretation of hazardous waste rules. HTP is an oxidizer and therefore a potential fire hazard. However, combustible mixtures are required, and concerns are moot on a small scale due to heat dissipation. For example, wet spots on cloth and absorbent paper will stop small flames, since HTP has a high heat capacity. Ground-based HTP storage containers must have a vent port or a relief valve, since gradual decay to oxygen and water causes pressure buildup.

Materials Compatibility and Decay in Storage

Compatibility between HTP and materials of construction includes two separate problems to be avoided. HTP exposure can cause material degradation, as occurs with many polymers. Secondly, the rate of HTP decay varies widely with exposure to different surfaces. In both cases, detrimental effects require significant periods of time. Therefore, compatibility must be quantified and considered in context, rather than being treated as a yes or no question. For example, a thrust chamber may be constructed of a metal which would be considered incompatible for tankage.

Historical work includes compatibility tests with material samples in glass containers of HTP.⁹ In support of present efforts, small sealed containers have been constructed of materials to be tested. Monitoring pressure and total mass indicates decay and the amount of leakage or permeation. In addition, effects such as

swelling or weakening become readily apparent since the container wall material is stressed by pressure.

Fluoropolymers such as PTFE (polytetrafluoroethylene), PCTFE (polychlorotrifluoroethylene), and PVDF (polyvinylidene fluoride) do not degrade in HTP. They also result in slow decay of the propellant, so these materials make sense for tank coatings, liners, or bladders, if months to years of storage are required. Similarly, fluoroelastomer o-ring seals (standard "Viton") and fluorinated greases are suitable for long term HTP exposure. Polycarbonate plastic is surprisingly unaffected by HTP. This non-brittle material has been used where its transparency is an asset. This includes prototype parts which are internally complex, and tanks where the liquid level must be visible (see Figure 4).

Decay in contact with Al-6061-T6 is only a few times faster than with the most compatible aluminum alloys. The former is strong and readily available, whereas the latter have little useful strength. Bare aluminum (e.g. Al-6061-T6) surfaces are preserved for many months in contact with HTP. This is in contrast to water, which oxidizes aluminum.

Contrary to historically recommended practice, complex and hazardous cleaning operations do not appear to be essential for most purposes. Most parts used with HTP in the present work were merely washed with mild detergent and water at 110 F. Preliminary results indicate that this can be nearly as good as recommended cleaning procedures. In particular, 35% nitric acid overnight only decreased the decay rate in a PVDF sample by 20% over a 6-month period.

It is readily calculated that 1% decay of HTP raises the pressure of a sealed 10% ullage volume to nearly 600 psi. Considering these numbers, the loss of performance through reduced HTP concentration is far less a concern than pressure safety.

Planning space missions with HTP requires careful consideration of the possible need for venting. If operation of the propulsion system begins within days to weeks after launch, the ullage volume may immediately increase by several fold. Bare metal tanks would make sense for such satellites. Obviously, the sealed storage period includes time during prelaunch operations.

It is unfortunate that regulations which have evolved along with the use of highly toxic propellants tend to prohibit automatic vent valves on flight hardware. Costly active pressure monitoring is often used. The notion of

increasing safety by prohibiting safety valves is contrary to normal terrestrial practice with pressurized fluid systems. Depending on which launch vehicle is used, this issue may need to be addressed.

If necessary, decay can be kept to 1% per year or lower. In addition to material choice, decay rates are strongly dependent on temperature. It may even be possible to store HTP indefinitely if it is permitted to freeze on long space missions. It does not expand and rupture hardware upon freezing as water does.

Since HTP decays on surfaces, higher volume-to-surface ratios can increase storage life. Comparative tests with 5 cc samples and 300 cc vessels have confirmed this. One test with distilled 85% HTP in a 300 cc PVDF vessel had a decay rate at 70 F of .05% per week, or 2.5% per year. Extrapolating to 10 liter tanks is consistent with decay below 1% per year at 20 C.

In other comparative tests in PVDF and with PVDF coatings on aluminum, HTP having 80 ppm of concentrated stabilizers decayed only 30% slower than the distilled propellant. It isn't bad news that stabilizers wouldn't greatly improve long term storage in flight tanks. As discussed in the next section, these impurities are quite detrimental to thruster operation.

Thruster Development

A planned microspacecraft required 0.1 g maneuvering for a 20 kg mass, or 4.4 lb thrust in vacuum. Since many of the features of conventional 5-lb thrusters were not needed, a custom development was undertaken. Numerous publications^{4&10&11} have addressed HTP catalyst packs. Mass fluxes near $250 \text{ kg-m}^{-2} \text{ s}^{-1}$ ($21 \text{ lb-in}^{-2}\text{-min}^{-1}$) are often quoted. Sketches of Bell thrusters used on Mercury and Centaur indicate only a fourth of this was used for thrust levels as low as 1 lb. A 9/16 inch diameter catalyst chamber bore was chosen here. A mass flux of $100 \text{ kg-m}^{-2} \text{ s}^{-1}$ would permit almost 5 lb thrust at 140 s Isp.

Silver Catalyst

Silver wire cloth and silver plated nickel screen have been used extensively in the past. A nickel wire base increases temperature capability (for >90% HTP) and may be cheaper on a large scale. Pure silver was chosen here to eliminate the plating step and because the soft metal is easily cut into strips then punched into circular pieces. Avoiding concerns of surface erosion was also helpful.

Available screen having 26 and 40 wires per inch was tested (respective wire diameters .012 and .009 inch).

The precise surface composition and mechanism of activity are not understood, as evidenced by various unexplained and conflicting statements in the literature. The catalytic action of new silver surfaces can be promoted by samarium nitrate and heat.¹¹ This compound decomposes to samarium oxide but might also oxidize silver. Other accounts additionally refer to activating plain silver with nitric acid,¹² which dissolves silver but is also an oxidizer. An even simpler notion is that plain silver catalyst packs can simply improve with use. This was found to be true, and led to useful catalyst without samarium nitrate.

Silver oxide (Ag_2O) is brownish-black and silver peroxide (Ag_2O_2), is gray-black. These colors appeared in sequence, suggesting that the silver became more heavily oxidized. The darkest color was associated with the best catalytic activity. In addition, the surface appeared much rougher than new silver under a stereo light microscope.

A simple activity test was found to be helpful. Individual silver screen circles (9/16 inch diameter) were placed in drops of HTP on a stainless steel sheet. Silver screen as purchased caused slow fizzing. The most active catalyst would repeatedly (10 times) produce a steam peak within 1 second.

The present study has not proven that oxidized silver is the catalyst, or that the observed darkening results primarily from oxidation. It is notable that both oxides of silver are known to decompose at relatively low temperatures. The excess of oxygen during thruster operation could shift the equilibrium, however. Experimentation attempting to ascertain the importance of oxidation and surface roughness was inconclusive. This included surface analysis by X-ray Photoelectron Spectroscopy (XPS), also called Electron Spectroscopy Chemical Analysis (ESCA). Attempts were also made to rule out the possibility that the new silver as purchased simply had surface contamination which inhibited catalytic activity.

Informal tests indicated that neither samarium nitrate nor its solid decomposition product (presumed to be oxide) catalyzes HTP decomposition. This suggests that the samarium nitrate treatment may work by oxidizing the silver. However, it has also been heard (without scientific evidence) that samarium oxide treatment prevents reaction product gas bubbles from remaining attached to the surface. In the present work, demonstrating lightweight thrusters and systems ultimately received a higher priority than solving catalyst mysteries.

Thruster Design

Stainless steel welded construction has been the traditional approach to HTP thrusters. The high thermal expansion of silver results in compression, followed by a gap along the chamber wall after cooling. Anti-channeling baffle rings are typically recommended so liquid can't bypass the screen pack.

Instead, good results were obtained here with thrust chambers made of free-cutting brass (copper alloy C36000). In addition to easy fabrication, its thermal expansion closely matches silver's. Excellent strength (50 ksi) is maintained at the decomposition temperature of 85% HTP, nearly 1200 F. This benign temperature also limits soakback temperatures to within the capability of an aluminum injector.

This choice of easily-worked materials and a readily produced HTP concentration appears to be a local optimum in design trade space. Note that 100% HTP would melt both the catalyst and chamber wall. This provides an example of a cost-performance compromise. It is noteworthy that bronze chambers are used on the RD-107 and RD-108 engines of the highly successful Soyuz launch vehicle.¹³

Figure 3 shows a lightweight design which bolted directly to the liquid valve manifold of a miniature maneuvering vehicle. At left is the 4 gram aluminum injector with its fluoroelastomer seals. The 25-gram silver screen pack was separated for two views. At right is the 2-gram catalyst support plate. The total mass of the parts shown was approximately 80 grams. One of these thrusters was used for terrestrial maneuvering tests of a 25 kg developmental microsatellite. It has performed as expected, including a 3.5 kg total propellant throughput with no apparent degradation.

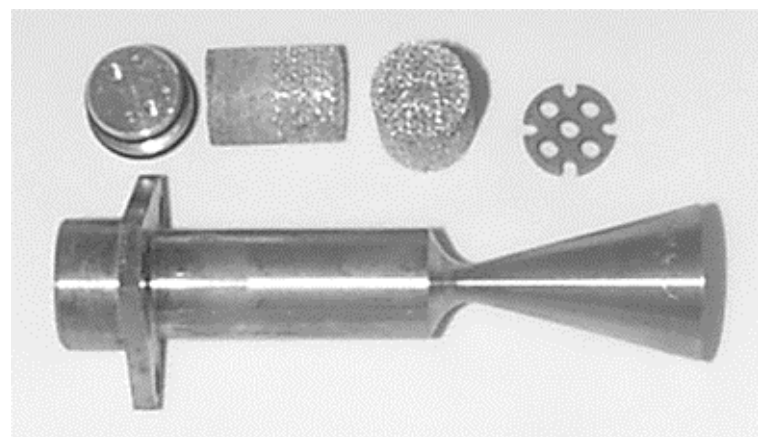

Figure 3. Monopropellant HTP thruster.

A 150 gram commercial direct-acting solenoid valve having a 1.2 mm orifice and a 25 ohm coil actuated at 12 VDC proved to be satisfactory. Wetted valve surfaces consisted of stainless steel, aluminum, and Viton. The total mass compares favorably to >600 grams for the 3-lb thruster used for Centaur attitude control prior to 1984.

Thruster Testing

The development test thruster was slightly heavier to accommodate several features such as a longer catalyst pack. It also had a bolt-on nozzle so that the tight-fitting pack could be easily pushed out with a press. Just upstream of the nozzle were instrument ports for pressure and gas temperature.

Figure 4 shows the setup ready for testing. Straightforward benchtop experiments were enabled by minimal propellant hazards, low thrust, atmospheric operation, and simple instrumentation. The safety enclosure consists of half-inch polycarbonate panels on an aluminum frame, with ample ventilation. The panels were rated for 365,000 N-s/m² of sectional momentum. For example, a 100 gram fragment moving supersonically at 365 m/s would stop if the impact area is 1 cm².

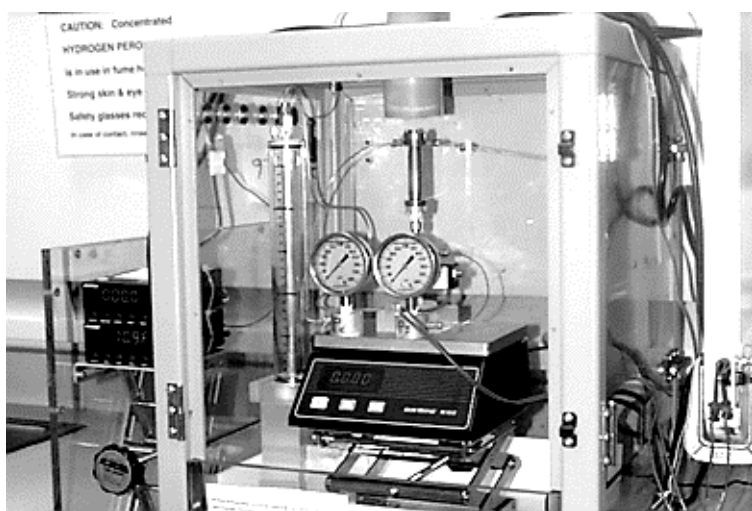

Figure 4. Thrust stand setup in benchtop safety enclosure.

In the photograph, the thrust chamber is oriented vertically just below an exhaust duct. Gauges for injector inlet and chamber pressures sit atop the platform scale which measures thrust. Digital readouts for elapsed time and temperature are just outside the safety enclosure. Thruster valve actuation also lit a small LED array. Data recording consisted of placing all readouts within the field of a video camcorder. A final measurement was done by applying a thermally-sensitive crayon line along the length of the catalyst chamber. The color changed above 800 F.

The HTP run tank is directly to the left of the thrust scale on a separate support, so its changing mass does not affect

thrust measurements. It was verified using calibration weights that the tubing loop feeding the thruster is sufficiently flexible to maintain accuracy within ± 0.01 lb. The tank was fabricated from large polycarbonate tubing and graduated so that the falling liquid level could be noted for calculating delivered Isp.

Thruster Performance

The experimental thruster was operated numerous times during 1997. Early tests used a restrictive injector and a small nozzle throat, at very low pressures. Thruster quality was found to be strongly correlated with the single-screen catalyst activity tests. After reliable decomposition was obtained, tank pressure was standardized at 300 psig. All tests began with both the hardware and propellant at 70 F.

Initial pulsing was needed to avoid a wet start having visible exhaust. Typically, a <50% duty cycle for the first 5 s was used, but as little as 2 s was possible. Subsequently, 5-10 additional seconds of continuous thrusting resulted in a complete warmup. Results included 1150 F gas temperatures, within 50 F of the theoretical number. Ten second periods of steady conditions were used to calculate Isp. Specific impulse was 100 s, which is likely to have improved with an optimized nozzle shape, and would certainly be much higher in a vacuum.

The length of the silver screen pack was successfully reduced from a conservative 2.5 inches to 1.7 inches. The final design included 9 holes drilled 1/64 inch in the flat injector face. A 1/8 inch nozzle throat diameter delivered 3.3 lb atmospheric thrust at 220 psig chamber pressure with 255 psig between the valve and injector.

The distilled propellant (Table 1) yielded consistent operation with steady pressure readings. After 3 kg of propellant throughput and 10 cold starts, the 800 F point along the chamber wall remained at 1/4 inch from the injector face. In contrast, longevity was unacceptable with 80 ppm of impurities. Chamber pressure oscillations at ~ 2 Hz worsened to $\pm 10\%$ after only 0.5 kg of throughput. The 800 F point receded to over an inch from the injector.

Several minutes in 10% nitric acid restored the catalyst to good condition. While this appeared to remove some silver as well as contamination, activity was better than when new silver screen was simply treated with nitric acid.

It should be noted that while the warmup time was seconds, much shorter pulses were possible with a hot thruster. The dynamic response of a 5 kg liquid propulsion subsystem on a linear track indicated pulse times shorter

than 100 ms, with impulse bits on the order of 1 N-s. Specifically, displacement was approximately ± 6 mm at 3 Hz, limited by control speed.

System Options

Figure 5 shows a number of possible propulsion schematics, and it is by no means exhaustive. The liquid systems are all candidates for implementation with HTP, and bipropellant versions of each are possible. Those in the top row are often used on satellites, with conventional propellants. The center row shows how gas jets can be added for attitude control. Advanced concepts having potentially lighter hardware with the least stored gas are shown in the lower row. The tank walls are illustrated to indicate the different pressure levels typical of each system. Also note that symbols differ for liquid thrusters and gas jets.

Conventional Options

Option A has been used on some of the smallest satellites, because it is simple and cold gas jets (valves with nozzles) can be very lightweight and compact. It has also been used on large space vehicles, e.g. the nitrogen attitude control system on Skylab in the 1970's.

Option B is the simplest liquid system, and it has been flown many times with monopropellant hydrazine. A fixed quantity of pressurant typically occupies a quarter of the liquid tank at launch. The gas expands as the mission proceeds, so the pressure is said to "blow down." However, falling pressure reduces both thrust and Isp. The maximum liquid tank pressure occurs on the launch pad, which drives tank mass for safety. A recent example is the Lunar Prospector spacecraft, which had approximately 130 kg of hydrazine and 25 kg of propulsion hardware.

Option C is widely used with conventional toxic monopropellant and bipropellants. For the smallest satellites, gas jets would need to be added for attitude control, as explained previously. For example, adding cold gas jets to system C results in option D. A nitrogen and HTP system of this type was built at LLNL to permit safe nontoxic maneuvering tests of prototype microsats.¹

Warm Gas Attitude Control

To reduce the quantity of stored gas and its tank mass, warm gas attitude control jets make sense for the smallest systems. At thrust levels below 1 lb, existing gas jets are lighter than monopropellant liquid thrusters by an order of

magnitude (Figure 1). Valving gas can provide smaller impulse bits than valving liquid. However, carrying stored inert gas is inefficient due to the large volume and pressure vessel mass required. For these reasons, it is desirable to generate attitude control gas from a liquid as satellite designs shrink. This has not been done in space, but option E was implemented with hydrazine on a tiny test system as noted previously.³ The level of component miniaturization achieved was remarkable.

To reduce hardware mass further and simplify packaging, it is desirable to entirely avoid having gas storage vessels. Option F is potentially very interesting for miniature HTP systems. If a long on-orbit storage period is required prior to operation, it could be launched unpressurized. Depending on the ullage volume, the tank size, and tank material, the system could be tailored to pressurize itself over a predetermined time period.

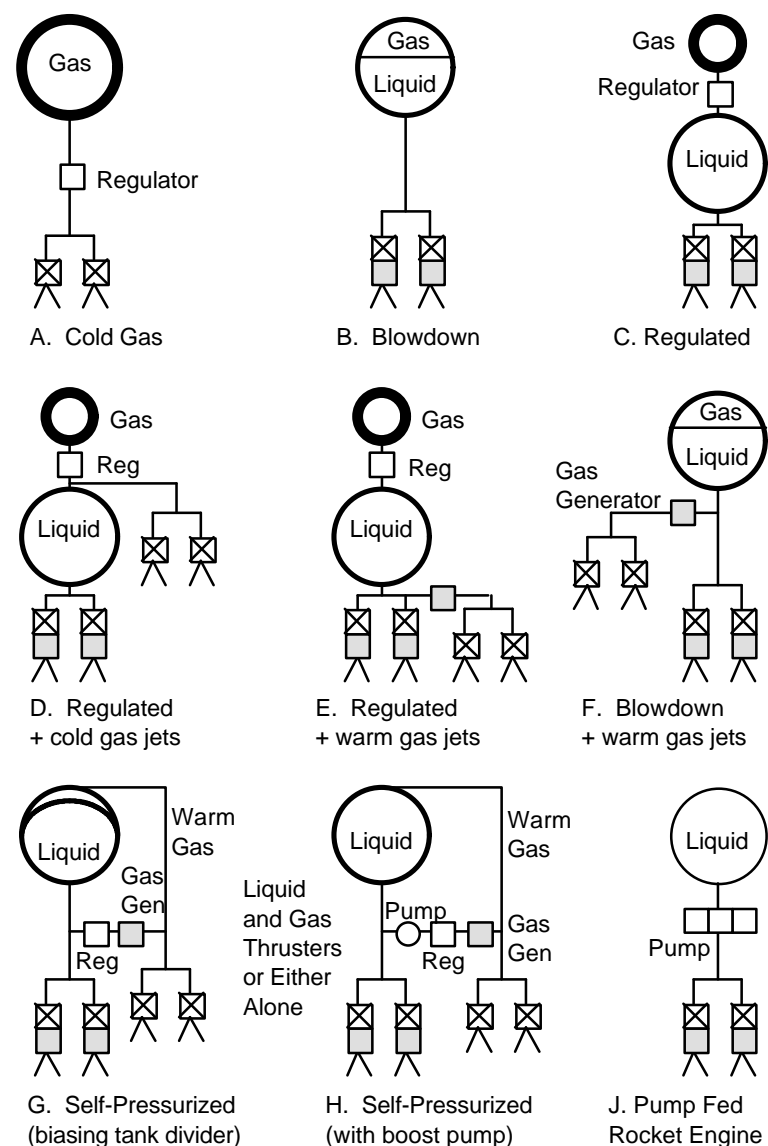

Figure 5. Simplified schematics of propulsion systems.

In option D, separate propellant sources for maneuvering and attitude control make it necessary to partition the two propellant budgets in advance. Systems E and F which make warm attitude control gas from the maneuvering

liquid have greater mission flexibility. For example, unused maneuvering propellant may be used to prolong the life of a satellite having an active pointing requirement.

Self Pressurizing Concepts

Only the advanced options in the last row of Figure 5 dispense with gas storage bottles while providing a constant system pressure as propellant is expended. They can be launched unpressurized or at low pressures, which can reduce liquid tank mass. The absence of both high pressure gas and pressurized liquids enhances launch site safety. This might permit a major cost reduction to the extent that commercial quality hardware is deemed to be safe with minimal pressure and toxicity. All thrusters on these systems draw from a single propellant supply, for maximum mission flexibility.

Options G and H could be referred to as "warm gas pressurized," or "blowdown-pumpup," as well as "gas-from-liquid", or "self-pressurizing" liquid propulsion systems. In order to controllably pressurize a tank with some of its own reacted propellant, a pressure boost capability is needed.

Option G uses a pressure-biased tank, so that liquid is delivered above the gas pressure. This can be done with a differential area piston or an elastically-loaded diaphragm which separates the gas and liquid. Acceleration could possibly be used, e.g. gravity in a terrestrial application or centripetal acceleration on a spinning spacecraft. Alternatively, option H works with any tank. A pressure boosting pump provides for circulation through the gas generator and back to the tank ullage.

In both cases, the liquid regulator prevents the positive feedback loop from generating arbitrarily high pressures. An additional valve in series with the regulator is required prior to system operation. It could later be used to control system pressure to any level below the regulator set pressure. For example, orbit change maneuvers would be done at full pressure. Reduced pressures at other times would permit more accurate 3-axis pointing, while conserving propellant to extend satellite lifetime (see Appendix).

Differential area boost capability in both pumps and tanks has been experimented with and documented numerous times over the years. In 1932, Robert H. Goddard et al built a bellows pump driven by a bellows engine to operate with liquid and gaseous nitrogen. Several efforts between 1950 and 1970 considered options G and H for atmospheric flight.¹⁴⁻¹⁶ This type of need emphasizes

compactness to minimize drag. These developments were apparently overshadowed by the widespread use of solid rockets. More recently, self-pressurizing systems using hydrazine and differential pistons have been tested with new improvements for specialized applications.^{17&18}

Self-pressurizing liquid tank systems have not been seriously considered for long term operation on spacecraft. There are several technical issues which require the lifetime thrust profile to be well characterized, in order to design a successful system. For example, catalyst material suspended in the pressurant gas could decompose propellant within the tank. A tank separator as in option G would be needed for applications which require long quiescent periods after initial propulsive maneuvering.

The thrust duty cycle is also important for thermal reasons. In Figure 5G and 5H, the heat of reaction in the gas generator is lost to the surroundings during long term operation at a low duty cycle. This is consistent with using soft seals in the warm gas components. High temperature metal seals would have higher leakage rates, but they would only be needed if the duty cycle for warm gas jets is extreme. Questions such as the thickness of insulation and thermal mass of components would need to be answered with good knowledge of the intended thrust profile.

Pump Fed Engines

In Figure 5J, a pump delivers propellant from a low pressure tank to a high pressure thrust chamber. This option provides the greatest maneuvering capability, and is routinely applied to launch vehicle stages. Both v and acceleration can be high, since neither the tank nor the engine are heavy. The pump must be designed for a very high power-to-weight ratio in order to justify its use.

While Figure 5J is oversimplified, it is included here to illustrate that it is fundamentally different from option H. The latter's pump is used in an auxiliary capacity, and has different design requirements from an engine pump.

Ongoing activity includes efforts toward testing pump fed rocket engines with HTP. Indications are that low-cost repetitive nontoxic testing can result in an even greater degree of simplicity and reliability than demonstrated previously by a pump-fed hydrazine system.¹⁹

Self-Pressurizing Tank System Prototype

While progress is being made toward implementing systems H and J in Figure 5 with HTP propellant, option G is the simplest and has been tested first. Some different

hardware is required, but the technological overlaps enhance synergistic development efforts. For example, the temperature and lifetime capability of fluoroelastomer seals, fluorinated greases, and aluminum alloys is of keen interest to all three system concepts.

Figure 6 shows the low cost test hardware, which uses a differential piston tank made from a length of 3 inch diameter by .065 wall aluminum tubing, with ends held in place by snap rings. Welds are avoided, to reduce cost and to simplify post-test inspections and system reconfiguration.

This self-pressurizing HTP system has been tested using commercial solenoid valves and low cost instrumentation, in a manner similar to thruster development testing. A system schematic diagram corresponding to the hardware is sketched in Figure 7. In addition to the gas immersion thermocouple shown, temperatures were measured on the tank and gas generator.

The tank is configured so that its liquid pressure is slightly higher than that of its pressurant. Numerous starts have been demonstrated using an initial air charge at 30 psig. When the control valve is opened, flow through the gas generator delivers steam and oxygen to the pressurant end of the tank. The system's first order positive feedback results in an exponential pressure rise until the liquid regulator shuts at 300 psi.

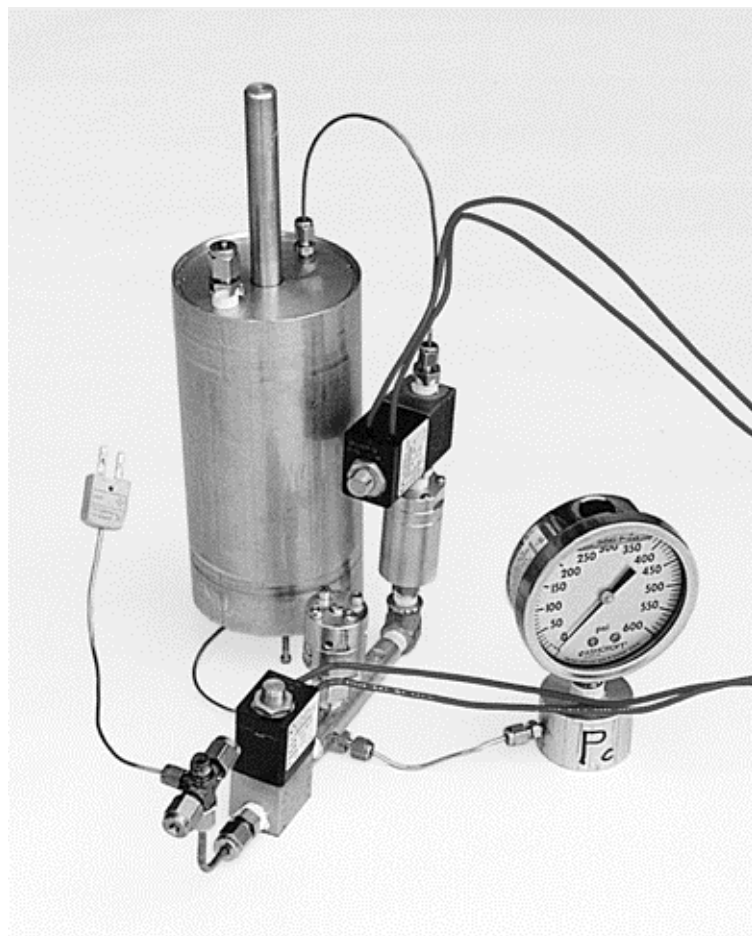

Figure 6. Self pressurizing HTP test system hardware.

Sensitivity to inlet pressure is unacceptable for the gas pressurant regulators used currently on satellites (Figure 5A & C). In a self-pressurizing liquid system, the regulator inlet pressure remains within a narrow range. Therefore, the complex art of conventional aerospace regulator design is avoided here. The 60 gram regulator has only four turned parts in addition to springs, seals, and fasteners. It includes a soft seal for positive shutoff. This simple axial flow design is possible because it need not be pressure balanced with respect to the inlet.

The gas generator is also simpler by virtue of system requirements. At 10 psi differential pressure or less, the flow is low enough that injector design for the catalyst chamber is not an issue. Additionally, the absence of a check valve at the gas generator inlet resulted in only small ~1 Hz oscillations of the decomposition reaction. The correspondingly small amounts of reverse flow during initial startup of the system did not heat the regulator above 100 F.

The first tests did not use a regulator, and demonstrated that system pressure could be controlled to any level between the seal friction threshold and the pressure safety limit. This system flexibility can be used to reduce attitude control thrust during most of a satellite's life, for reasons noted earlier.

One finding which is obvious in retrospect is that the tank operates hotter if there are system pressure oscillations due to low-bandwidth control without the regulator. A check valve at the tank pressurant port would eliminate the additional heat flux resulting from oscillatory flow. Such a valve would also prevent the tank from functioning as a gas accumulator for the attitude control jets, but this is not necessarily an important effect.

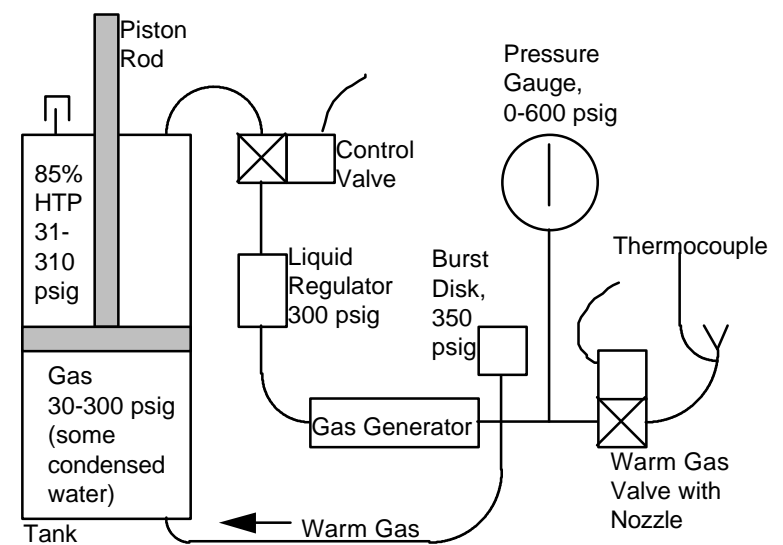

Figure 7. Self pressurizing HTP test system schematic.

Although the aluminum parts would melt at the reaction temperature of 85% HTP, hardware temperatures are reduced by heat losses in combination with low or intermittent gas flow. The tank shown in the photograph has remained well below 200 F during pressure regulated operation. Simultaneously, the gas outlet temperature has exceeded 400 F during relatively aggressive pulsing of the warm gas valve.

This gas outlet temperature is significant, because it indicates that the water remained in the superheated steam state at the internal system pressure. The range 400 to 600 F appears to be ideal because it is cool enough for low cost lightweight hardware (aluminum and soft seals), while being hot enough to realize most of the performance potential of the propellant portion used for gas jet attitude control. During periods of operation at reduced pressure, an additional advantage is that the minimum temperature required to avoid water condensation also falls.

In order to operate within the desired temperature range as much as possible, parameters such as insulation thickness and thermal mass of components should be tailored to the required thrust profile. As expected, condensed water was found in the pressurant end of the tank after experiments, but this unused mass is a small fraction of the system propellant load. Even if all the water condenses in the attitude control gas stream as well, 40% of the propellant mass is still gaseous (for 85% HTP). Even this worst case can be better than nitrogen, since the water is not heavier than an expensive state-of-the-art nitrogen tank.

The prototype hardware shown in Figure 6 is obviously far from being a complete propulsion system. Liquid thrusters of the type described in this paper would be connected to the tank's liquid port, as indicated in Figure 5G, for example.

Plans for Pumped Pressurization

A robust gas-driven pump is being developed to test the concept shown in Figure 5H. Unlike the differential piston tank, it must refill during operation. This requires liquid check valves, but also automatic gas valves for venting at the end of the stroke and repressurizing.

A pair of pumping chambers operating alternately is planned instead of the minimum single unit. This will permit continuous operation of a warm gas attitude control subsystem at a steady pressure. The goal is to permit greater flexibility in tank selection, for reduced mass. The

pump will be powered by some of the gas generator output.

Discussion

The lack of available propulsion options for smaller satellites is not news, and different possibilities are being pursued.²⁰ The various attempts to solve the problem can benefit greatly from a better understanding of propulsion trades among users, and a better understanding of satellite thrust timelines among propulsion developers.

This paper has considered the possibility of hydrogen peroxide liquid propulsion using low cost materials and methods applicable on a small scale. The results could certainly be applied to monopropellant hydrazine, but also wherever HTP might serve as an oxidizer in nontoxic bipropellant combinations. The latter options would include hypergolic alcohol fuels discussed in Reference 6, as well as liquid or solid hydrocarbons which combust upon contact with the hot oxygen in decomposed HTP.

Low-tech HTP propulsion technology as represented by this paper can be directly applicable to experimental satellites and other spacecraft on the smallest scales. It was only a generation ago that low earth orbit and even deep space were explored using what was essentially new and experimental propulsion technology. For example, the lunar Surveyor landing propulsion system included numerous soft seals which might be considered unacceptable today, but were adequate to meet mission needs.²¹ Currently, scientific instruments and electronics have been miniaturized, but propulsion technology is not adequate for either tiny satellites or small lunar landers.

The message here is that custom hardware can be developed for particular needs. It is understood that this conflicts with the "heritage" philosophy which typically governs the selection of satellite subsystems. Inherent to this conventional wisdom is the assumption that details are not well enough understood to design and fly new hardware. This paper was inspired by the notion that repetitive low-cost testing can make the necessary knowledge affordable to small satellite engineers. Along with understanding both satellite needs and propulsion technology comes the potential relaxation of unnecessary requirements.

Acknowledgments

Numerous individuals contributed to the author's familiarity with hydrogen peroxide rocket technology. They include Fred Aldridge, Kevin Bollinger, Mitchell

Clapp, Tony Friona, George Garboden, Ron Humble, Jordin Kare, Andrew Kubica, Tim Lawrence, Martin Minthorn, Malcolm Paul, Jeff Robinson, John Rusek, Jerry Sanders, Jerry Sellers, and Mark Ventura.

The research was part of the Clementine II Program and the Microsat Technologies Program at LLNL, supported by the U.S. Air Force Research Laboratory. This work was sponsored by the U.S. Government and performed by the University of California Lawrence Livermore National Laboratory under Contract W-7405-Eng-48 with the U.S. Department of Energy.

References

1. Ledebuhr, A.G., J.F. Kordas, et al, "Autonomous, Agile, Micro-Satellite Technology for Use in Low Earth Orbit Missions," SSC98-V-1, The 12th Annual Utah State University Small Satellite Conference, 1998.
2. Whitehead, J.C., "Mars Ascent Propulsion Options for Small Sample Return Vehicles," AIAA 97-2950, July 1997.
3. Acampora, K.J., and H. Wichmann, "Component Development for Micropropulsion Systems," AIAA 92-3255, 1992.
4. McCormick, J.C., "Hydrogen Peroxide Rocket Manual," FMC Corporation, circa 1963.
5. Bolonkin, A., "The Development of Soviet Rocket Engines," ISBN 1-55831-130-0, Delphic Associates Inc., 1991.
6. Rusek, J.J., M.K. Minthorn, et al, "Non-Toxic Homogeneous Miscible Fuel (NHMF) Development for Hypergolic Bipropellant Engines," Proceedings of the 6th Annual AIAA/BMDO Technology Readiness Conference, San Diego CA, August 1997.
7. Bloom, R., "On the Hazards of Concentrated Hydrogen Peroxide," Jet Propulsion, p 666, June 1957.
8. Satterfield, C.N., G.M. Kavanagh, & H. Resnick, "Explosive Characteristics of Hydrogen Peroxide Vapor," Industrial and Engineering Chemistry 43:11, pp 2507-2514, 1951.
9. Anon., "Hydrogen Peroxide Handbook," Rocketdyne document number R-6931, Air Force Rocket Propulsion Laboratory report nr AFRPL-TR-67-144, 1967.
10. Davis, N.S. & J.C. McCormick, "Design of Catalyst Packs for the Decomposition of Hydrogen Peroxide," American Rocket Society paper nr 1246-60. In Bollinger, L.E., et al (eds) "Progress in Astronautics and Rocketry," vol 2, "Liquid Rockets and Propellants," Academic Press, 1960.
11. Garboden, G., "Fabrication of a Catalyst Pack for a 1500 lb Thrust Hydrogen Peroxide Rocket," RRS News, 53:1, Reaction Research Society, pp. 1-9, March 1996.
12. Rusek, J.J., "New Decomposition Catalysts and Characterization Techniques for Rocket Grade Hydrogen Peroxide," J. Propulsion and Power, 12:3, pp. 574-579, May 1996.
13. Glushko, V.P., "Rocket Engines of the Gas Dynamics Laboratory—Experimental Design Bureau," NASA Technical Translation F-16847, 1976. "Raketnyye Dvigateli GDL-OKB," Moskow, Novosti Press, 1975.
14. Cumming, J.M., G.P. Sutton, et al, "Liquid Propellant Rocket," US Patent 2789505, 1957.
15. Greiner, L., "Differential Area Piston Pumping System," US Patent 2918791, 1959.
16. Waddington, J.F, "Rocket Projectiles," US Patent 4762293, 1988 (filed 1968).
17. Simpkin, A.J., M.L. Chazen, et al, "KEW Divert Vehicle Propulsion System Technology Verification and Risk Reduction Program Phases I-V," vol 1, TR-PL-12360, Atlantic Research Corporation. Also Air Force Astronautics Laboratory report nr AFAL-TR-88-020, November 1988.
18. Maybee, J.C., and D. Krismer, "A Novel Design Warm Gas Pressurization System," American Institute of Aeronautics and Astronautics, AIAA 98-4014, 1998.
19. Maybee, J.C., D.G. Swink, and J.C. Whitehead, "Updated Test Results of a Pumped Monopropellant Propulsion System," Proceedings of the JANNAF Propulsion Meeting, Monterey CA, November 1993.
20. Sellers, J.J., et al, "A Low-Cost Propulsion Option for Small Satellites," Journal of the British Interplanetary Society, 48:3, pp. 129-138, March 1995.
21. Pasley, G.F., "Surveyor Spacecraft Vernier Propulsion System Survival in the Lunar Environment," J Spacecraft & Rockets 6:12, 1969.

22. Doody, D., "Basics of Spaceflight: Attitude Control," The Planetary Report, p. 23, Sep-Oct 1995.

Appendix—Attitude Control Scaling Equations

An analysis was performed to explore the scaleability of fully propulsive 3-axis attitude control systems. Their thrusters must deliver minimum impulse bits before the maximum permitted angular excursion is exceeded, on each axis. It was not necessary to consider control equations. Any control algorithm appropriate for a fixed minimum thruster pulsewidth will result in limit cycle operation. A prime example is the Voyager spacecraft, which continues to pulse its hydrazine thrusters a few times per hour. This keeps the antenna pointed toward earth from outside the solar system, 21 years after launch.²²

The question of interest here is how does satellite scaling affect pointing accuracy and propellant consumption. It is assumed that there is one set of attitude thrusters operating at a fixed thrust level, and they are sized to react the maximum disturbance torque which results from firing a main maneuvering thruster. The equations below are for one axis only, since each axis is independent. This analysis is concerned with cruise lifetime for a given pointing requirement. It does not consider propellant needed to react disturbance torques or for deliberate rotations. In general, a satellite's rotational needs include four items: 1. continuous cruise pointing (for solar array and/or antenna orientation); 2. fine pointing (e.g. for imaging); 3. deliberate rotations; and 4. offsetting disturbance torques generated by translational maneuvers. While the rotational propellant budget must include all these, item 1 will dominate for long cruise lifetimes.

<u>Given Parameters</u>	<u>Symbol</u>	<u>mks Units</u>
spacecraft mass	M	kg
spacecraft radius of gyration	r	m
maneuvering thrust	F	N
maneuver thrust c.g. offset	d	m
attitude jet moment arm	l	m
attitude jet specific impulse	Isp	m/s
minimum thrust pulse time	τ	s
allowed angular excursion	θ (\pm from center)	rad
cruise lifetime	t	s
<u>Calculated Parameters</u>	<u>Symbol</u>	<u>mks Units</u>
spacecraft moment of inertia	J	kg-m ²
maneuver disturbance torque	T	N-m
attitude jet thrust	f	N
minimum ACS impulse bit	Ibit	N-s

min angular rate change	$\Delta\omega$	rad/s
limit cycle angular rate	ω	rad/s
limit cycle period	p	s
nr of pulses in cruise life	n	dimensionless
total propulsive impulse	I	N-s
propellant mass	m	kg

The following equations are written from dynamics etc.

$$J=Mr^2 \quad T=Fd \quad Ibit = ft$$

$$f=2T/l \quad (\text{assume factor of 2 for control authority})$$

$$\Delta\omega = Ibit / J = 2T\tau / J \quad \omega = \Delta\omega / 2 \quad (\text{symmetry assumed})$$

$$p = 4\theta / \omega \quad n = 2t / p \quad I = n \text{ Ibit} \quad m = I / Isp$$

Combining equations yields:

$$p = \frac{4 \theta M r^2}{\tau F d} \quad \text{and} \quad m = \frac{t F^2 d^2 \tau^2}{M Isp \theta r^2 l}$$

Dividing by satellite mass and rearranging leaves:

$$\frac{m}{M} = \frac{t}{Isp \theta} \left(\frac{F}{M} \right)^2 \frac{d^2 \tau^2}{r^2 l}$$

This last equation shows the fraction of satellite mass which must be allocated to attitude-keeping propellant on one axis. As expected, it increases with desired life, t, and pointing precision, 1/ θ . The second factor on the right hand side is independent of scaling considerations assuming equal maneuvering acceleration, F/M, for large and small satellites. However, the third factor indicates inverse proportionality to the cube of spacecraft dimensions ($r^2 l$). This can potentially be compensated for by aligning the maneuvering thruster more precisely (reducing d), and using faster valves (reducing τ). The dependence on r and l quantifies the usefulness of spreading a tiny spacecraft's mass and thrusters over larger dimensions.

There are limits to all the above measures which mitigate the detrimental effects of scaling laws. Another solution is to use two sets of attitude control thrusters, in which case T=Fd applies only to the coarse set. Fine thrusters would be used otherwise to conserve propellant and extend life. However, doubling the number of attitude control thrusters is not particularly attractive for a tiny satellite. An alternative would be to reduce propulsion system pressure during cruise, which effectively reduces the thrust levels of a single set of gas jets.

Biography

The author earned undergraduate degrees in both science and engineering from Caltech. He received a doctorate in mechanical dynamics and controls from the University of California, Davis, in 1987. At the Lawrence Livermore National Laboratory, he led the development of miniature pump-fed rocket engines. Since 1995, he has contributed toward understanding unsolved propulsion problems, such as SSTO and Mars departure.