

Aug. 11, 1953

H. MAISNER

2,648,190

INITIATION OF PROPELLANT DECOMPOSITION

Filed March 5, 1948

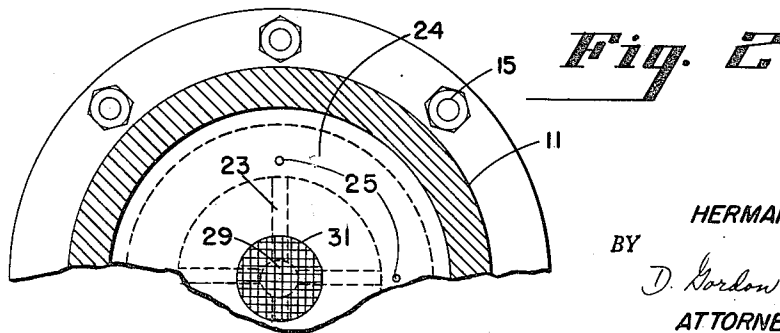
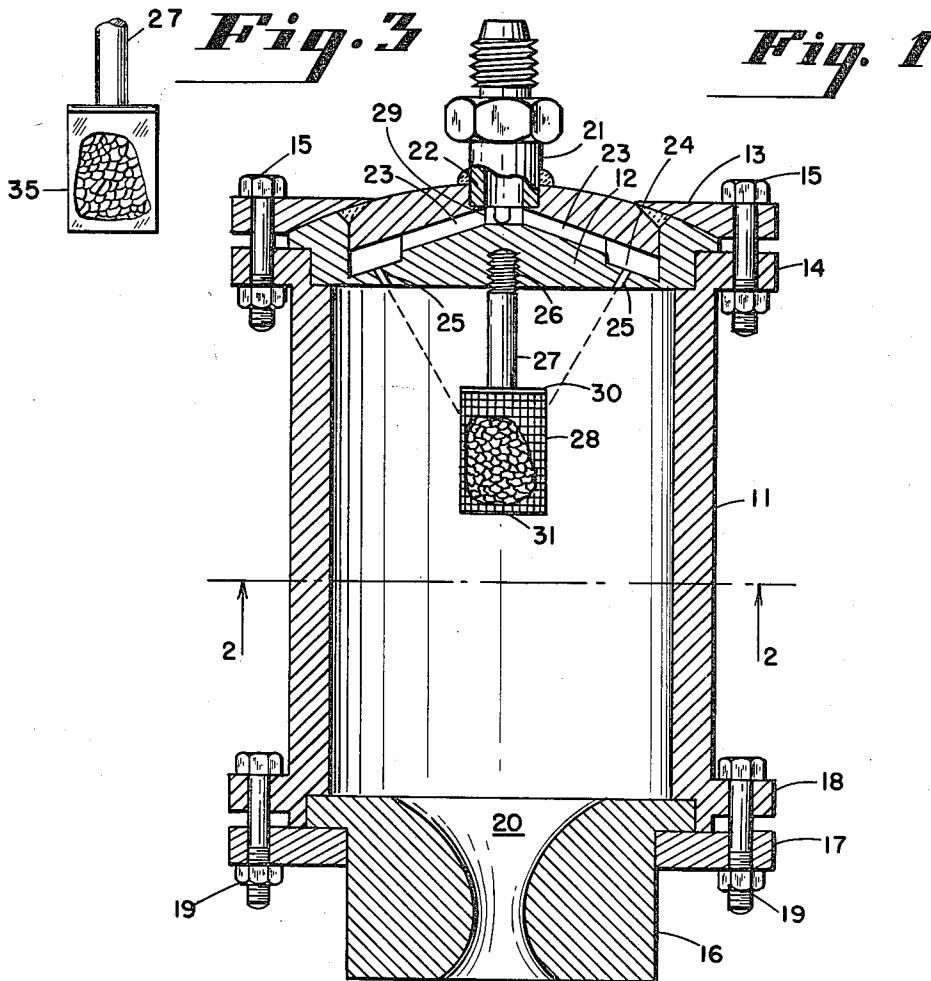

INVENTOR.  
HERMAN MAISNER  
BY  
*D. Gordon Angus*  
ATTORNEY

# UNITED STATES PATENT OFFICE

2,648,190

## INITIATION OF PROPELLANT DECOMPOSITION

Herman Maisner, Los Angeles, Calif., assignor,  
by mesne assignments, to Aerojet-General Cor-  
poration, Cincinnati, Ohio, a corporation of  
Ohio

Application March 5, 1948; Serial No. 13,106

3 Claims. (Cl. 60—35.4)

1

This invention relates to the ignition of propellant injected into rocket motors, and has for its principal object to provide a positive, simple, dependable and safe means for initiating the decomposition or combustion of the propellant which serves as fuel for the motor.

Rockets and rocket motors operated by liquid propellant generally comprise a reaction chamber having an exhaust nozzle and a propellant injector through which the liquid propellant is squirted into the reaction chamber, where it is ignited and decomposed or burned. This forms large amounts of gases at high pressure which escape through the nozzle at high velocity to produce the reaction force.

Some liquid propellants, such as nitroparaffins, are particularly desirable for operating a rocket motor, as they are self-combustible because they contain the oxygen required for their decomposition. The nitroparaffin most commonly used has been mononitromethane, ordinarily called nitromethane; and sometimes a mixture of nitromethane and nitroethane has been used.

It is highly desirable that decomposition should start the instant that the nitroparaffin enters the reaction chamber; otherwise, an undesirably large quantity of the liquid propellant may accumulate in the chamber before it starts to decompose with the result that an explosion may result when it finally does react. Difficulty has been experienced, however, in satisfactorily initiating the decomposition of the nitroparaffins when the fuel is introduced into a cold motor chamber.

A number of expedients have been heretofore proposed for insuring the decomposition of the nitroparaffin at the instant that it is injected into the rocket motor chamber. One of these involves the use of catalysts capable of assisting the decomposition of the nitroparaffin. These, however, have not always proven as rapid and certain in starting as is usually desired; and furthermore, some of them require additional ignition means to start the reaction.

Another expedient sometimes used is to introduce the nitroparaffin into a chamber having an atmosphere of oxygen gas and igniting the mixture by suitable electrical ignition means such as a spark plug or hot spot. The use of oxygen is not always desirable, however, due to the bulky containers necessary for storing the oxygen under pressure and also because of undesirably high temperatures that may be generated when the nitromethane is decomposed in the presence of oxygen.

2

Another expedient heretofore used for initiating the recomposition of nitromethane has been to spray a stream of nitromethane into a reaction chamber into which there is also injected a mixture of concentrated hydrogen peroxide and concentrated solution of calcium permanganate. The resulting reaction initiates the decomposition.

In accordance with my invention, I provide an improvement in initiating the decomposition of liquid nitroparaffins, and particularly those nitroparaffins which are classed as monopropellants. I carry out my invention by use of a mass of a novel kind of catalyst which I have found especially effective.

A feature of my invention is the positioning of the catalyst mass in the reaction chamber at a point where the stream of nitroparaffin from the injector nozzles will strike it. I prefer to do this by placing the catalyst in a small container within the chamber, which may, for example be a cylinder or the like, having a mesh-like wall, such as a metal screen or other mesh-like fabric. An alternative way would be to place the catalyst in some sort of suitable capsule or the like which would dissolve upon contact by the nitroparaffin.

My invention is also featured by the use of an especially effective catalyst material. This feature is based on my discovery that solid lithium aluminum tetrahydride is especially effective in causing the spontaneous decomposition of liquid nitroparaffins, for example, nitromethane, nitroethane, nitropropane, nitrobutane, etc., combinations of the above, such as mixtures of nitromethane and nitroethane, as well as liquid poly-nitroparaffins such as tetranitromethane, dinitroethane, etc. The above catalyst is particularly useful when employed in initiating the decomposition of the so-called monopropellant type of nitroparaffin such as nitromethane and dinitroethane. I have found that whenever the nitroparaffin touches the surface of this catalyst, the catalyst becomes extremely hot, even to the point of incandescence.

The immediate localized heat thus produced at the catalyst instantaneously initiates the decomposition of the nitroparaffin; and the resulting heat of the decomposition will be sufficient to insure the continued decomposition of the nitroparaffin liquid which continues to enter the chamber.

The foregoing and other features of my invention will be better understood from the following detailed description and the accompanying drawing in which:

3

Fig. 1 shows the cross section of a rocket motor provided with an ignitor charge according to my invention;

Fig. 2 shows a broken cross sectional view of the reaction chamber taken on the line 2—2 of Fig. 1; and

Fig. 3 shows a soluble form of capsule which may be used for the ignitor charge according to this invention.

Referring to the drawing there is shown a rocket motor operated by a liquid nitroparaffin injected into the chamber which is particularly designed for operation with nitromethane.

The motor comprises a combustion chamber 11, preferably cylindrical in shape. One end of the reaction chamber 11 is provided with a closure cap 12 which is held in place by annular ring 13 having its lower surface shaped to conform with the outline of cap 12. Ring 13 is secured to an annular shoulder 14 located at the upper edge of the reaction chamber 11 by a plurality of bolts 15.

The opposite end of the reaction chamber 11 is provided with a nozzle member 16, preferably of the De Laval type having a converging-diverging orifice 20, which is held securely in place by a retainer ring 17 attached by a plurality of bolts 19 to a flange 18 which is located at the lower end of the reaction chamber 11. A hollow cylindrical conduit 21 enters through the top of the closure member and extends inwardly into the closure a sufficient distance to communicate with a cavity 29. A plurality of channels 23 radiate through the closure member from the cavity 29; and the outer ends of the channels 23 terminate in an annular groove 24, symmetrically located around the longitudinal axis of member 12. A number of injector orifices 25 open from the groove into the reaction chamber 11; and the axes of these orifices are positioned at an angle with the longitudinal axis of closure member 12 so that the streams escaping through the injector intersect at a predetermined point within the reaction chamber.

It should be understood that the closure member just described is shown by way of example, rather than of limitation, and that some other suitable form of chamber or closure member or injector arrangement may be used instead, if desired.

The face of the closure member 12 opposite the one to which fitting 21 is attached, is provided with a threaded hole 26, preferably centrally positioned, which receives a stud 27. The stud is made preferably of some metal or alloy having a high heat resistance, and can be molybdenum or other metal capable of resisting the high temperature encountered in the reaction chamber while the motor is in operation.

A container 28 is secured to the lower end of stud 27 and is filled with material which acts as a catalyst for the injected propellant. The wall of the container is shown in the drawings as being metal screen; but it should be understood that some other suitable material of a more or less similar nature may be employed instead. The upper end of the cylinder is closed by a circular piece of solid metal 30 provided with a central hole which permits attachment to the stud 27; and the other end is closed by a disc of metal screen 31 which is secured to the mesh cylinder by suitable means such as brazing, welding, soldering, etc.

The catalyst container shown in the drawings is illustrated by way of example, and it should be

4

understood that other suitable means of locating the catalyst charge in the proper position within the reaction chamber may be employed, if desired. Thus the metal screen may be replaced by a plastic screen or a capsule made of plastic or other material that is readily soluble in the nitroparaffin propellant. Fig. 3 shows such an arrangement of a soluble capsule 35 containing the catalyst material, the capsule being secured to the lower end of the stud 27 in place of the metal screen container 28 shown in Fig. 1. When the nitroparaffin strikes the capsule, the latter will immediately dissolve and the nitroparaffin will cause the catalyst to become incandescent the instant the liquid nitroparaffin touches its surface.

The catalyst material which I have discovered to be most effective for use with the nitroparaffin propellant and particularly with nitromethane or a mixture of nitromethane and nitroethane, is lithium aluminum tetrahydride. The most effective way of putting this catalyst material in the container within the chamber is in the form of solid particles. This will present a large number of surfaces which in their aggregate will have a large surface area, which will facilitate the incandescent heating effect of the catalyst upon the liquid propellant injected against it.

In the operation of the motor, the liquid nitroparaffin, for example, nitromethane, nitroethane, nitropropane, nitrobutane; combinations of the above, such as mixtures of nitromethane and nitroethane as well as the liquid polynitroparaffins such as tetranitromethane, dinitroethane etc., is injected into the reaction chamber through the spray nozzle. The direction of the injector orifices causes it to contact the catalytic mass and the catalyst immediately becomes incandescent, developing heat enough to initiate the burning of the nitroparaffin which strikes it. This incandescence is accompanied by volatilization or burning away of the catalyst, so that after the chamber temperature has risen sufficiently to cause sustained spontaneous combustion of the nitroparaffin, the catalyst is decomposed.

The chamber temperature at which positive decomposition of nitromethane is insured is generally in the neighborhood of 500° F.; and above this temperature any nitromethane entering the chamber will be spontaneously decomposed even though the catalyst mass may have been completely volatilized or destroyed by the heat.

When the nitromethane thus decomposes spontaneously, the chamber temperature rises above 500° F., as the temperature that is generally developed by the stoichiometric decomposition of nitromethane into its molecular components is generally in the order of 2500° K.

When the motor has ceased to operate, a new catalytic charge can be introduced into the chamber, thus preparing the motor for a subsequent start.

It will be recognized that by my invention I have provided a simple, inexpensive and positive means for initiating the decomposition of a monopropellant nitroparaffin such as nitromethane without the necessity of employing additives which may undesirably sensitize the nitromethane or require the addition of outside oxidizer which materially increases the weight and bulk of the installation.

My ignitor does not require any outside starting means such as electrical sparks, oxygen or other previously known forms of initiators, since my catalyst material substantially glows when

5

coming in contact with the nitroparaffin and remains incandescent even though the nitroparaffin is sprayed thereon in large volumes.

A further advantage of my invention resides in the fact that a relatively simple injection mechanism can be used since it need inject only the nitroparaffin; and is not required also to inject some other substance to aid starting.

I claim:

1. The method of initiating the decomposition of a liquid nitroparaffin which comprises spraying the liquid nitroparaffin on the surface of solid lithium aluminum tetrahydride.

2. The method of initiating the decomposition of a liquid monopropellant nitroparaffin in a rocket motor having a reaction chamber and an exhaust nozzle, which comprises spraying the nitroparaffin against a catalytic mass comprising solid lithium aluminum tetrahydride within said reaction chamber.

3. The method of initiating the decomposition

6

of nitromethane in a rocket motor having a reaction chamber and an exhaust nozzle which comprises spraying the nitromethane against a catalytic mass comprising solid lithium aluminum tetrahydride within said reaction chamber.

HERMAN MAISNER.

References Cited in the file of this patent

UNITED STATES PATENTS

Number	Name	Date
2,301,044	Heard et al. ....	Nov. 3, 1942
2,319,620	Mather .....	May 18, 1943
2,380,391	Bates .....	July 31, 1945
2,433,932	Stosick .....	Jan. 6, 1948
2,433,943	Zwicky et al. ....	Jan. 6, 1948
2,438,261	Utterback .....	Mar. 23, 1948

FOREIGN PATENTS

Number	Country	Date
384,386	France .....	Feb. 3, 1908